



Piper Aircraft, Inc.
2926 Piper Drive
Vero Beach, FL, U.S.A. 32960

SERVICE NO. 1093B LETTER

Date: November 28, 2017

(S) (M)

MAINTENANCE ALERT

Service Letter (SL) 1093B supersedes SL 1093A in its entirety. Aircraft that were previously made compliant with SL 1093 or SL 1093A are in compliance with SL 1093B.

SUBJECT:

ELECTRICAL CONTACTOR REPLACEMENT KIT

REASON FOR REVISION:

SL 1093B includes revised instructions in which the contactor replacement kit for some models has changed.

MODELS AFFECTED:

PA-18/18A, PA-18-105/-125/-135
and PA-18A/AS-125/-135
PA-18-150 Super Cub

PA-22-125 Tri-Pacer
PA-22-135 Tri-Pacer
PA-22-150/-160 Tri-Pacer
PA-22-108 Tri-Pacer
PA-23 Apache
PA-23-160 Apache
PA-23-235 Apache
PA-23-250 Aztec

PA-E23-250 Aztec
PA-24 Comanche
PA-24-250 Comanche
PA-24-260 Comanche
PA-24-400 Comanche
PA-28-140 Cherokee
PA-28-150/-160/-180 Cherokee
PA-28-180 Cherokee/Challenger/Archer
PA-28-235 Cherokee Pathfinder
PA-28-151 Warrior
PA-28-161 Warrior II

SERIAL NUMBERS AFFECTED:

18-1 thru 18-7632
18-3771, 18-3781 thru 18-9015,
18-7309016 thru 18-8309025, 1809001 thru 1809113,
19-1 thru 19-3
22-1 thru 22-532
22-534 thru 22-2424
22-2378, 22-2425 thru 22-6351
22-8000 thru 22-9848
23-1 thru 23-1176, 23-1178 thru 23-1182
23-1177, 23-1183 thru 23-2046
27-505 thru 27-662
27-1 thru 27-504, 27-623 thru 27-4916,
27-7304917 thru 27-8154030
27-2505 thru 27-8154030
24-1 thru 24-3687
24-1, 24-103 thru 24-3687
24-3642, 24-4000 thru 24-5034
26-2 thru 26-148
28-20001 thru 28-26946, 28-7125001 thru 28-7725290
28-03, 28-1 thru 28-4377
28-4378 thru 28-5859, 28-7105001 thru 28-7505260
28-10001 thru 28-11378, 28-7110001 thru 28-7710089
28-7415001 thru 28-7715314
28-7716001 thru 28-8616057, 2816001 thru 2816109

ATA/JASC: 2400

(OVER)

PA-28-161 Cadet	2841001 thru 2841365
PA-28-161 Warrior III	2816110 thru 2816125, 2842001 & Up
PA-28-181 Archer II	28-7690001 thru 28-8690056, 28-8690061, 28-8690062, 2890001 thru 2890205
PA-28-181 Archer III	2843001 & Up
PA-28-201T Turbo Dakota	28-7921001 thru 28-7921095
PA-28-236 Dakota	28-7911001 thru 28-8611008, 2811001 thru 2811050
PA-28R-180 Arrow	28R-30002 thru 28R-31270, 28R-7130001 thru 28R-7130013
PA-28R-200 Arrow/Arrow II	28R-35001 thru 28R-35820, 28R-7135001 thru 28R-7635545
PA-28R-201 Arrow III	28R-7737002 thru 28R-7837317, 2837001 thru 2837061, 2844001 & Up
PA-28R-201T Turbo Arrow III	28R-7703001 thru 28R-7803373, 2803001 & 2803012
PA-28RT-201 Arrow IV	28R-7918001 thru 28R-8218026
PA-28RT-201T Turbo Arrow IV	28R-7931001 thru 28R-8631005, 2831001 thru 2831038
PA-30 Twin Comanche	30-2 thru 30-2000
PA-31/-31-300 Navajo	31-2 thru 31-861, 31-7300901 thru 31-7400989, 31-7400991 thru 31-7401268
PA-31/-31-325 Navajo	31-7400990, 31-7512001 thru 31-8312019
PA-31-350 Chieftain	31-5002 thru 31-5004, 31-7305005 thru 31-8452024
PA-31-350 T-1020	31-8253001 thru 31-8553002
PA-31P Pressurized Navajo	31P-1 thru 31P-80, 31P-7300110 thru 31P-7400230, 31P-7530001 thru 31P-7730012
PA-32-260 Cherokee Six	32-01, 32-1 thru 32-14, 32-16 thru 32-20, 32-22 thru 32-1297, 32-7100001 thru 32-7800008
PA-32-300 Cherokee Six	32-15, 32-21, 32-40000 thru 32-40974, 32-7140001 thru 32-7940290
PA-32-301 Saratoga	32-8006002 thru 32-8606023, 3206002 thru 3206088
PA-32-301T Turbo Saratoga	32-8024001 thru 32-8424002
PA-32-301 FT Piper 6X	3232001 & Up
PA-32-301XTC Piper 6XT	3255001 & Up
PA-32R-300 Cherokee Lance	32R-7680001 thru 32R-7880068
PA-32R-301(14-V) Saratoga SP	32R-8013001 thru 32R-8613006, 3213001 thru 3213041
PA-32R-301 Saratoga II HP	3213042 thru 3213103, 3246001 & Up
PA-32R-301T Turbo Saratoga SP	32R-8029001 thru 32R-8629008, 3229001 thru 3229003
PA-32R-301T Saratoga II TC	3257001 & Up
PA-32RT-300 Lance II	32R-7885001 thru 32R-7985105
PA-32RT-300T Turbo Lance II	32R-7887001 thru 32R-7987126
PA-34-200 Seneca	34-7250001 thru 34-7450220
PA-34-200T Seneca II	34-7570001 thru 34-8170092
PA-34-220T (14-V) Seneca III	34-8133001 thru 34-8633031, 3433001 thru 3433172
PA-34-220T(28-V) Seneca III	3448001 thru 3448035
PA-34-220T Seneca IV	3448038 thru 3448079, 3447001 thru 3447029
PA-34-220T Seneca V	3449001 & Up

PA-36-285/-300/-375 Pawnee Brave	36-736001 thru 36-8160023, 36-7802001 thru 36-8320025
PA-38-112 Tomahawk	38-78A001 thru 38-82A0122
PA-44-180 Seminole	44-7995001 thru 44-8195020, 4495001 thru 4495013, 4496001 & Up
PA-44-180T Turbo Seminole	44-8107001 thru 44-8207020
PA-46-310P Malibu	46-8408001 thru 46-8608067, 4608001 thru 4608140
PA-46-350P Malibu Mirage	4622001 thru 4622200, 4636001 & Up
PA-46R-350T Matrix	4692001 & Up

COMPLIANCE TIME: Whenever a subject contactor replacement is required

APPROVAL: The engineering aspects of this service document have been shown to comply with the applicable Federal Aviation Regulations and are FAA approved.

PURPOSE: This service letter provides instructions to replace old style contactors with new style contactors that feature insulated mounting flanges. In addition, the grounding technique of some contactors will change from a "case ground" to a dedicated ground terminal.

Piper's supplier revised their contactor product line, changing the design to electrically isolate the contactor case from aircraft ground. Kit – Electrical Contactor Replacement, part number (P/N) 767-390, "Kit Instructions" (attached), provides all of the contactor part numbers and/or kit numbers for old and new replacement contactors. Refer to the kit to determine what additional parts need to be purchased. Affected contactors are six-volt (6V) intermittent contactors, 12-volt continuous contactors, 12-volt intermittent contactors, and 24-volt continuous contactors for the affected aircraft. If old-style contactors are still available, they may still be installed.

Piper P/N 767-390 "Kit Instructions" identifies the kits that include parts for the first-time replacement of affected old style contactors (with bare metal mounting flanges) with new style contactors (with insulated mounting flanges).

INSTRUCTIONS:

1. When an old style contactor fails and a replacement old style contactor of the same number is not available, refer to Piper Kit P/N 767-390 "Kit Instructions" (attached) to identify the appropriate kit part number for converting to a new style contactor.

NOTE: First-time replacement of an old style contactor with the new style may require additional parts or modifications which are defined in the kit instructions.

2. Replace contactor(s) per Kit P/N 767-390, Section I, "Contactor Replacement Procedure."
3. Make a logbook entry documenting compliance with this service letter.

MATERIAL REQUIRED: As defined by Kit – Electrical Contactor Replacement, Piper P/N 767-390 (attached)

AVAILABILITY OF PARTS: Your Piper Approved Service Center

EFFECTIVITY DATE: This service letter is effective upon receipt.

SUMMARY: Please contact your Piper Approved Service Center to make arrangements for compliance with this service letter in accordance with the compliance time indicated.

NOTE: Please notify the factory of any address/ownership corrections. Changes should include aircraft model, serial number, and current owner's name and address.

Corrections and/or changes should be directed to:

PIPER AIRCRAFT, INC.
Att'n: Customer Service
2926 Piper Drive
Vero Beach, FL 32960
or:
CustomerService@piper.com
Please include in subject line: "Aircraft ownership update"

PURPOSE:

TO PROVIDE HARDWARE AND INSTRUCTIONS FOR REPLACING OLD STYLE CONTACTORS WITH A NEW STYLE CONTACTOR WHICH FEATURES INSULATED MOUNTING FLANGES AND FOR SOME CONTACTORS CHANGING FROM "CASE GROUND" TO A DEDICATED GROUND TERMINAL WITH A GROUND WIRE..

BACKGROUND:

OUR SUPPLIER HAS CHANGED THEIR PRODUCT LINE OF CONTACTORS SUPPLIED TO PIPER BY CHANGING THE DESIGN TO ELECTRICALLY ISOLATE THE CONTACTOR CASE FROM AIRCRAFT GROUND.

NOTES:

- Ⓔ ⏏ REQUIRED FOR GROUNDING CONTACTOR.
- Ⓔ ⏏ INSTALLATION OF THE REPLACEMENT CONTACTOR WILL REQUIRE REPLACING EXISTING CONTACT TERMINALS WITH TERMINALS PROVIDED IN KIT.
- Ⓒ ⏏ REQUIRED WHEN REPLACING 12 VOLT AIRCRAFT STARTER CONTACTOR ONLY.

J	G	E	D	B	REV	REVISION	DRAFTSMAN	OHL	2/20/05		
AA	STK	RDM	OHL	OHL	BY		DESIGN ENGR.	OHL	2/20/05		
10/17	12/14	5/12	6/05	4/05	DATE		CHIEF ENGR.				
					APPD		PROGRAM MGR.	FRALEY	2/20/05		
	H	F	C	A	REV		METHODS				
	Z.S	RDM	OHL	OHL	BY		SCALE	NONE	LAST SECTION	OR	LAST VIEW
	4/15	8/04	4/05	3/05	DATE						
					APPD						

THIS DRAWING IS THE PROPERTY OF THE NEW PIPER AIRCRAFT, INC. AND ITS POSSESSION BY UNAUTHORIZED PERSONS SHALL NOT BE CONSTRUED AS PERMISSION TO REPRODUCE FOR SALE IN WHOLE OR IN PART ANY DEVICES SHOWN THEREON.

THE NEW PIPER AIRCRAFT, INC.
VERO BEACH, FLORIDA

DOA	
MANUFACTURING	
MATERIALS	

**KIT ~ ELECTRICAL
CONTACTOR REPLACEMENT**

KIT NO: 767-390 THRU 767-396, 767-399, 767-581

SHT. 1	DWG. NO.	88371	J
OF 15			

INDEX

TITLE PAGE Page 1

CONTACTOR REPLACEMENT
PROCEDURE Section I

IDENTIFYING OLD vs REPLACEMENT
CONTACTOR Section II

REPLACEMENT KITS &
HARDWARE KITS Section III

INSTALLATION INSTRUCTIONS Section IV
& UP

THE NEW PIPER AIRCRAFT, INC. VERO BEACH, FLORIDA		KIT ~ ELECTRICAL CONTACTOR REPLACEMENT	
KIT NO: 767-390 THRU 767-396, 767-399, 767-581	SHT. 2 OF 15	DWG. NO. 88371	REV. J

SECTION I: CONTACTOR REPLACEMENT PROCEDURE

When the existing contactor is in need of replacement, perform a visual inspection to identify the mounting flange configuration:

- non-insulated mounting flanges are bare metal.
- insulated mounting flanges are covered by black, over-molded plastic.

If the mounting flanges are non-insulated, proceed as follows:

- Exact replacement will be supplied, if available.
- If the exact replacement is not available, a suitable alternate part may be available. If the alternate part is available, it must be installed according to the model-specific instructions and the hardware specified in Section IV of this document.

If the mounting flanges are insulated, proceed as follows:

Refer to Section II of this document for the correct replacement part number. As this is an exact replacement part, no additional hardware kit is required.

THE NEW PIPER AIRCRAFT, INC. VERO BEACH, FLORIDA		KIT ~ ELECTRICAL CONTACTOR REPLACEMENT	
KIT NO: 767-390 THRU 767-396, 767-399, 767-581	SHT. 3 OF 15	DWG. NO. 88371	REV. J

SECTION II: IDENTIFYING OLD vs REPLACEMENT CONTACTOR

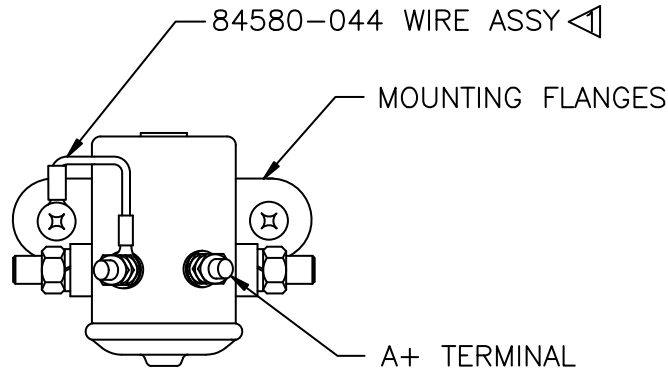

Ⓔ LAMAR CONTACTOR

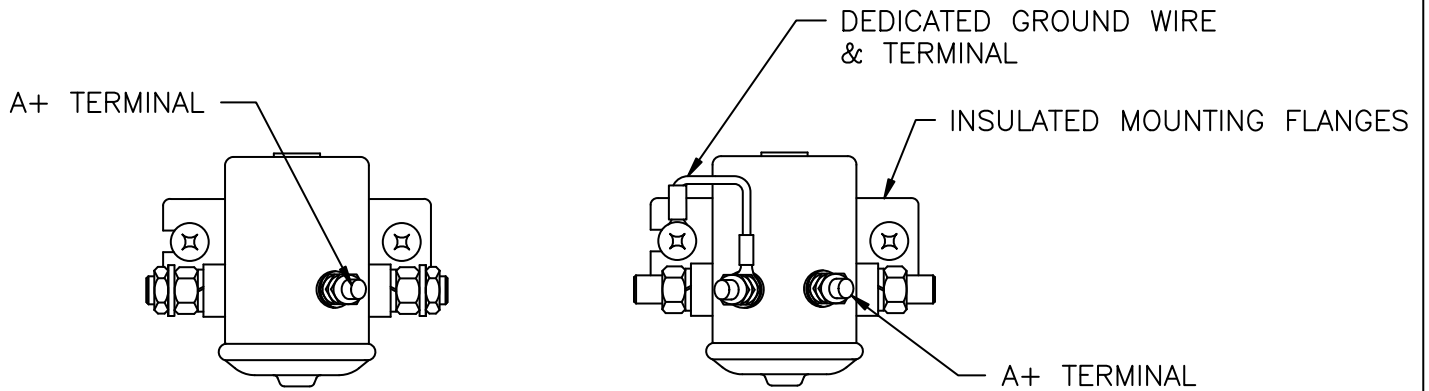

OLD CONTACTOR

WHITE RODGERS CONTACTOR

OLD CONTACTOR

REPLACEMENT CONTACTOR

Ⓔ	PAC 26898-002 (487-149) (6V INTERMITTENT)	→	PAC 26898-010 (602-850) (6V INTERMITTENT)
	PAC 26898-003 (487-152) (12V INTERMITTENT)	→	PAC 26898-008 (584-420) (12V INTERMITTENT)
	PAC 99130-002 (487-169) (6V INTERMITTENT)	→	PAC 99130-003 (602-847) (6V INTERMITTENT)
Ⓔ	PAC 26898-010 (602-850) (6V INTERMITTENT)	→	PAC 26898-013 (584-460) (12V INTERMITTENT)
Ⓔ	PAC 26898-008 (584-420) (12V INTERMITTENT)	→	PAC 26898-011 (584-461) (24V INTERMITTENT)
Ⓔ	PAC 99130-003 (602-847) (6V INTERMITTENT)	→	PAC 26898-013 (584-460) (12V INTERMITTENT)
			PAC 99130-004 (584-460) ◀ (12V INTERMITTENT)
Ⓔ	PAC 26898-006 (487-163) (6V INTERMITTENT)	→	PAC 26898-013 (584-460) (12V INTERMITTENT)

THE NEW PIPER AIRCRAFT, INC.
VERO BEACH, FLORIDA

KIT ~ ELECTRICAL
CONTACTOR REPLACEMENT

KIT NO: 767-390 THRU 767-396,
767-399, 767-581

SHT. 4
OF 15

DWG. NO.

88371

REV.

J

SECTION II: IDENTIFYING OLD vs REPLACEMENT CONTACTOR (CONTINUED)

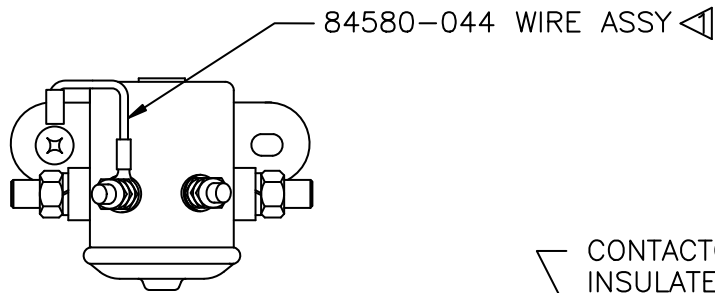

Ⓔ LAMAR CONTACTOR

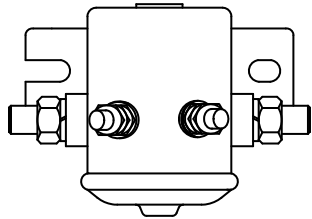

OLD CONTACTOR

CONTACTOR CHANGED TO INSULATED MOUNTING FLANGES

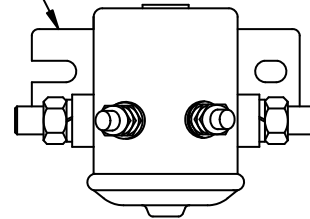

WHITE RODGERS CONTACTOR

OLD CONTACTOR

REPLACEMENT CONTACTOR

PAC 26898-005 (487-167)
(24V CONTINUOUS)

PAC 26898-009 (584-422)
(24V CONTINUOUS)

PAC PS50053-5-2 (484-373)
(12V CONTINUOUS)

PAC PS50053-5-3 (602-848)
(12V CONTINUOUS)

Ⓔ PAC 26898-009 (584-422)
(24V CONTINUOUS)

PAC 26898-012 (584-459)
(24V CONTINUOUS)

Ⓔ PAC PS50053-5-3 (602-848)
(12V CONTINUOUS)

PAC 99130-005 (584-458)
(12V CONTINUOUS)

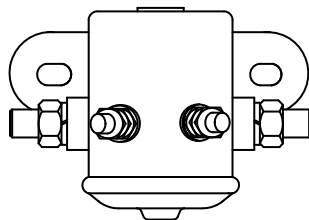

PAC 26898-004 (487-157)
(24V INTERMITTENT)

NOTE:

The 487-157 Contactor was not changed to include insulated mounting flanges. The contactor without insulated mounting flanges is available from our Dealer Network.

THE NEW PIPER AIRCRAFT, INC.
VERO BEACH, FLORIDA

KIT ~ ELECTRICAL
CONTACTOR REPLACEMENT

KIT NO: 767-390 THRU 767-396,
767-399, 767-581

SHT. 5
OF 15

DWG. NO.

88371

REV.

J

SECTION III: REPLACEMENT KITS & HARDWARE KITS

(E)	1	84580-044	WIRE ASSY			
	1	88371-007	HARDWARE KIT	2400	M	1530
	1	88371-002	KIT INSTRUCTIONS	2400	M	8110
(E)	1	584-460	CONTACTOR	12V INTERMITTENT	2400	P 1240
X		-006	CONTACTOR KIT	767-394	2400	M 1530
(E)	1	84580-044	WIRE ASSY			
	1	88371-007	HARDWARE KIT	2400	M	1530
	1	88371-002	KIT INSTRUCTIONS	2400	M	8110
(E)	1	584-458	CONTACTOR	12V CONTINUOUS	2400	P 1240
X		-005	CONTACTOR KIT	767-393	2400	M 1530
(E)	1	84580-044	WIRE ASSY			
	1	88371-007	HARDWARE KIT	2400	M	1530
	1	88371-002	KIT INSTRUCTIONS	2400	M	8110
(E)	1	584-459	CONTACTOR	24V CONTINUOUS	2400	P 1240
X		-004	CONTACTOR KIT	767-392	2400	M 1530
(E)	1	84580-044	WIRE ASSY			
	1	88371-007	HARDWARE KIT	2400	M	1530
	1	88371-002	KIT INSTRUCTIONS	2400	M	8110
(E)	1	584-461	CONTACTOR	24V INTERMITTENT	2400	P 1240
X		-003	CONTACTOR KIT	767-391	2400	M 1530
X		-002	KIT INSTRUCTIONS	767-390	2400	M 8110
QTY	ITEM NO.	ITEM NAME	DESCRIPTION	E-ITEM GROUP	ITEM TYPE	ITEM GROUP

THE NEW PIPER AIRCRAFT, INC.
VERO BEACH, FLORIDA

KIT ~ ELECTRICAL
CONTACTOR REPLACEMENT

KIT NO: 767-390 THRU 767-396,
767-399, 767-581

SHT. 6
OF 15

DWG. NO. 88371

REV. J

SECTION III: REPLACEMENT KITS & HARDWARE KITS (CONTINUED)

2	488-494	TERMINAL					
1	84580-044	WIRE ASSY					
1	88371-007	HARDWARE KIT		2400	M	1530	
1	88371-002	KIT INSTRUCTIONS		2400	M	8110	
1	584-460	CONTACTOR	12V INTERMITTENT	2400	P	1240	
1	-010	CONTACTOR KIT	767-581	2400	M	1530	
2	690-612	WASHER	NAS1149F0363P	2400	P	1140	
2	411-534	SCREW	MS35207-265	2400	P	1140	
2	85012-067	WASHER		2400	M	1520	
2	-009	HARDWARE KIT	767-399	2400	M	1530	
①	1	84580-044	WIRE ASSY				
	1	88371-007	HARDWARE KIT	2400	M	1530	
	1	88371-002	KIT INSTRUCTIONS	2400	M	8110	
①	1	584-460	CONTACTOR	12V INTERMITTENT	2400	P	1240
1	-008	CONTACTOR KIT	767-396	2400	M	1530	
2	690-669	WASHER	MS35335-33	2400	P	1140	
2	690-612	WASHER	NAS1149F0363P	2400	P	1140	
2	690-611	WASHER	NAS1149F0463P	2400	P	1140	
2	411-535	SCREW	MS35207-266	2400	P	1140	
2	411-534	SCREW	MS35207-265	2400	P	1140	
2	411-533	SCREW	MS35207-264	2400	P	1140	
2	415-538	SCREW	MS35206-248	2400	P	1140	
2	415-544	SCREW	MS35206-244	2400	P	1140	
2	404-530	NUT	MS21042-4	2400	P	1140	
2	400-003	BOLT	AN4-6A	2400	P	1140	
2	400-002	BOLT	AN4-5A	2400	P	1140	
2	401-266	BOLT	AN3-5A	2400	P	1140	
2	-007	HARDWARE KIT	767-395	2400	M	1530	
QTY	ITEM NO.	ITEM NAME	DESCRIPTION	E-ITEM GROUP	ITEM TYPE	ITEM GROUP	

THE NEW PIPER AIRCRAFT, INC.
VERO BEACH, FLORIDA

KIT ~ ELECTRICAL
CONTACTOR REPLACEMENT

KIT NO: 767-390 THRU 767-396,
767-399, 767-581

SHT. 7
OF 15

DWG. NO.

88371

REV.

J

SECTION IV: INSTALLATION INSTRUCTIONS

A. The following contactors have been changed to insulated mounting flanges. These contactors have always had a dedicated ground terminal and will not require a change to the electrical hookup. Longer attachment hardware will be required to accommodate the thicker mounting flanges.

1. OLD CONTACTOR

REPLACEMENT CONTACTOR

PAC 26898-005 (487-167)
(24V CONTINUOUS)

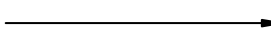

PAC 26898-009 (584-422)
(24V CONTINUOUS)

REPLACEMENT KIT: 767-392

PAC PS50053-002 (484-373)
(12V CONTINUOUS)

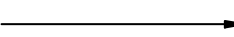

PAC PS50053-003 (602-848)
(12V CONTINUOUS)

REPLACEMENT KIT: 767-393

Ⓔ PAC 26898-009 (584-422)
(24V CONTINUOUS)

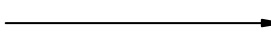

PAC 26898-012 (584-459)
(24V CONTINUOUS)

REPLACEMENT KIT: 767-392

REPLACEMENT KIT: 767-392

Ⓔ PAC PS50053-003 (602-848)
(12V CONTINUOUS)

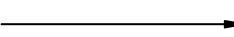

PAC 99130-005 (584-458)
(12V CONTINUOUS)

REPLACEMENT KIT: 767-393

REPLACEMENT KIT: 767-393

Ⓕ PAC 26898-006 (487-163)
(6V INTERMITTENT)

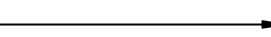

PAC 26898-013 (584-460)
(12V INTERMITTENT)

REPLACEMENT KIT: 767-581 ◁

1.1. Replacement approved for all Piper Model Aircraft that have PAC 26898-005, 484-373 contactors installed (ref. Parts Catalog).

NOTE

1. Compare removed mounting hardware with components supplied in kit. Select and use the appropriate hardware replacement which will be the same type, except for a longer length to accommodate the thicker mounting flanges. Discard the remaining unused hardware in the kit.

2. Reference: Replacement of the 26898-005 (487-167) External Power Contactor in the Electrical, Forward Panel Ass'y 89803-013 on Seneca PA-34-220T, Ser. No. 3449001 & up.

Installation of the replacement contactor will require spacer washers (order hardware kit 767-399) between the contactor and the mounting panel for clearance between the contactor mounting flanges and the hardware attaching the panel assembly to the aircraft frame.

THE NEW PIPER AIRCRAFT, INC. VERO BEACH, FLORIDA		KIT ~ ELECTRICAL CONTACTOR REPLACEMENT	
KIT NO: 767-390 THRU 767-396, 767-399, 767-581	SHT. 8 OF 15	DWG. NO. 88371	REV. J

SECTION IV: INSTALLATION INSTRUCTIONS (continued)

B. Following are the installation and wiring instructions for the replacement contactors that have been changed to insulated mounting flanges and the addition of a dedicated ground terminal and ground wire.

1. OLD CONTACTOR

REPLACEMENT CONTACTOR

PAC 26898-002 (487-149) (6V INTERMITTENT) —————> PAC 26898-010 (602-850) (6V INTERMITTENT)

REPLACEMENT KIT: 767-396

ⓐ PAC 26898-003 (487-152) (12V INTERMITTENT) —————> PAC 26898-008 (584-420) (12V INTERMITTENT)

REPLACEMENT KIT: 767-394

ⓐ PAC 99130-002 (487-169) (6V INTERMITTENT) —————> PAC 99130-003 (602-847) (6V INTERMITTENT)

REPLACEMENT KIT: 767-396

ⓔ PAC 26898-010 (602-850) (6V INTERMITTENT) —————> PAC 26898-013 (584-460) (12V INTERMITTENT)

REPLACEMENT KIT: 767-396

REPLACEMENT KIT: 767-396

ⓐ PAC 26898-004 (487-157) (24V INTERMITTENT) —————> PAC 26898-011 (584-461) (24V INTERMITTENT)

REPLACEMENT KIT: 767-391

ⓐⓐⓔ PAC 26898-008 (584-420) (12V INTERMITTENT) —————> PAC 26898-013 (584-460) (12V INTERMITTENT)

REPLACEMENT KIT: 767-394

REPLACEMENT KIT: 767-394

ⓔ PAC 99130-003 (602-847) (6V INTERMITTENT) —————> PAC 99130-004 (584-460) (12V INTERMITTENT)

REPLACEMENT KIT: 767-394

REPLACEMENT KIT: 767-394

1.1. Compare removed mounting hardware with components supplied in kit. Select and use the appropriate hardware replacement which will be the same type, except for a longer length to accommodate the thicker mounting flanges. Discard the remaining unused hardware in the kit.

1.2. Ground wire attachment.

1.2.a. PA-34 Series Aircraft

See View A for attachment of Ground Wire to airframe ground.

THE NEW PIPER AIRCRAFT, INC.
VERO BEACH, FLORIDA

KIT ~ ELECTRICAL
CONTACTOR REPLACEMENT

KIT NO: 767-390 THRU 767-396,
767-399, 767-581

SHT. 9
OF 15

DWG. NO.

88371

REV.

J

SECTION IV: INSTALLATION INSTRUCTIONS (continued)

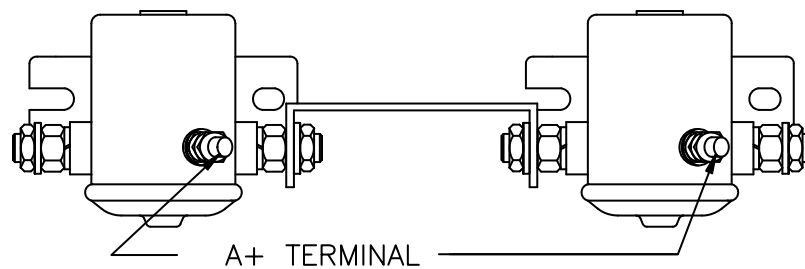

STARTER CONTACTOR ASSEMBLY (OLD CONTACTORS)

VIEW A (CONTINUED)

- PA-34-200 Ser. No. 34-7250001 & up
- PA-34-200T Ser. No. 34-7570001 & up
- PA-34-220T (14 VOLT) Ser. No. 34-8133001 & up
- PA-34-220T (28 VOLT) Ser. No. 3448005 & up
- PA-34-220T (28 VOLT) Ser. No. 3447001 & up
- PA-34-220T Ser. No. 3449001 & up

THE NEW PIPER AIRCRAFT, INC. VERO BEACH, FLORIDA		KIT ~ ELECTRICAL CONTACTOR REPLACEMENT	
KIT NO: 767-390 THRU 767-396, 767-399, 767-581	SHT. 10 OF 15	DWG. NO. 88371	REV. J

SECTION IV: INSTALLATION INSTRUCTIONS (continued)

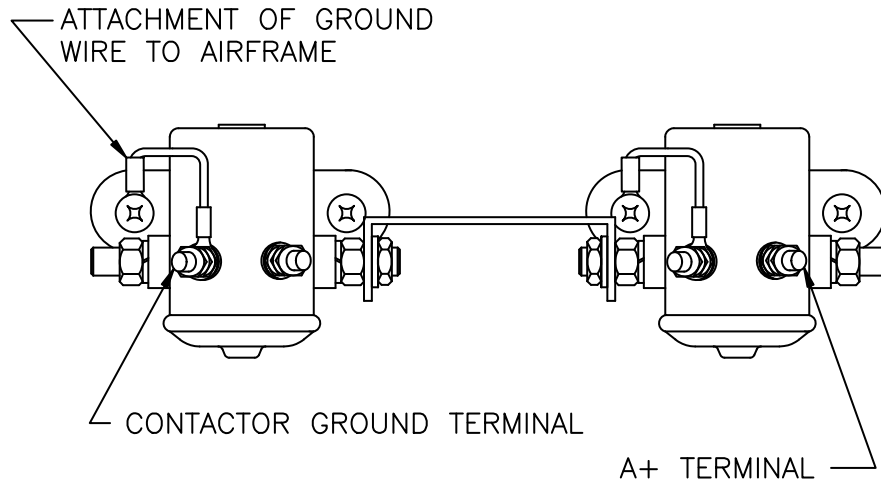

STARTER CONTACTOR ASSEMBLY (WHITE RODGERS)

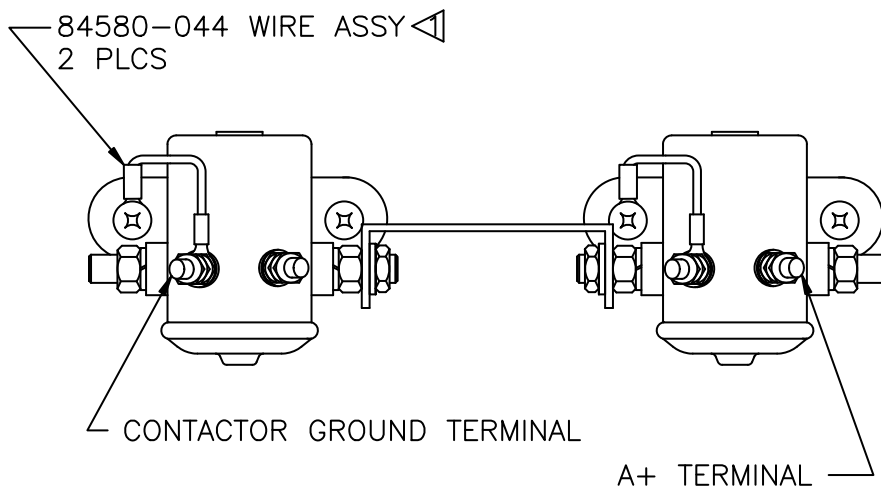

Ⓔ STARTER CONTACTOR ASSEMBLY (LAMAR)

VIEW A (CONTINUED)

- PA-34-200 Ser. No. 34-7250001 & up
- PA-34-200T Ser. No. 34-7570001 & up
- PA-34-220T (14 VOLT) Ser. No. 34-8133001 & up
- PA-34-220T (28 VOLT) Ser. No. 3448005 & up
- PA-34-220T (28 VOLT) Ser. No. 3447001 & up
- PA-34-220T Ser. No. 3449001 & up

THE NEW PIPER AIRCRAFT, INC. VERO BEACH, FLORIDA		KIT ~ ELECTRICAL CONTACTOR REPLACEMENT	
KIT NO: 767-390 THRU 767-396, 767-399, 767-581	SHT. 11 OF 15	DWG. NO. 88371	REV. J

SECTION IV: INSTALLATION INSTRUCTIONS (continued)

1.2.b. See View B for attachment of Ground Wire to airframe ground for the following aircraft.

- PA-18/18A, PA-18 "105"/"125"/"135" and
- Ⓒ PA-18A/AS "125"/"135" Ser. No. 18-1 THRU 18-7632
- PA-18 "150" Ser. No. 18-3771, 18-3781 THRU 18-9015, 18-7309016 THRU 18-8309025, 1809001 THRU 1809113, 19-1 THRU 19-3
- PA-22 -125 Ser. No. 22-1 THRU 22-532
- PA-22 -135 Ser. No. 22-534 THRU 22-2424
- PA-22 -150/160 Ser. No. 22-2378, 22-2425 THRU 22-6351
- PA-22-108 Ser. No. 22-8000 THRU 22-9848
- Ⓒ PA-23 Ser. No. 23-1 THRU 23-1176, 23-1178 THRU 23-1182
- PA-23-160, Ser. No. 23-1177, 23-1183 THRU 23-2046
- PA-23-235 Ser. No. 27-505 THRU 27-662
- PA-23-250 Ser. No. 27-1 THRU 27-504, 27-623 THRU 27-4916, 27-7304917 THRU 27-8154030
- PA-E23-250 Ser. No. 27-2505 THRU 27-8154030
- Ⓒ PA-24 Ser. No. 24-1 THRU 24-3687
- Ⓒ PA-24 250, Ser. No. 24-1, 24-103 THRU 24-3687
- Ⓗ PA-24-260, Ser. No. 24-3642, 24-4000 THRU 24-5034
- PA-24-400, Ser. No. 26-2 THRU 26-148
- PA-28-140 Ser. No. 28-20001 THRU 28-26946, 28-7125001 THRU 28-7725290
- PA-28-150/160/180 Ser. No. 28-03, 28-1 THRU 28-4377
- PA-28-180 Ser. No. 28-4378 THRU 28-5859, 28-7105001 THRU 28-7505260
- PA-28-235 Ser. No. 28-10001 THRU 28-11378, 28-7110001 THRU 28-7710089
- PA-28-151 Ser. No. 28-7415001 THRU 28-7715314
- PA-28-161 Ser. No. 28-7716001 THRU 28-8616057, 2816001 THRU 2816109
- PA-28-161(CADET) Ser. No. 2841001 THRU 2841365
- PA-28-161 Ser. No. 2816110 THRU 2816125, 2842001 & UP
- PA-28-181 Ser. No. 28-7690001 THRU 28-8690056, 28-8690061, 28-8690062, 2890001 THRU 2890205
- PA-28-181. Ser. No. 2843001 & UP
- PA-28-201T Ser. No. 28-7921001 THRU 28-7921095
- PA-28-236 Ser. No. 28-7911001 THRU 28-8611008, 2811001 THRU 2811050
- PA-28R-180 Ser. No. 28R-30002 THRU 28R-31270, 28R-7130001 THRU 28R-7130013
- Ⓒ PA-28R-200 Ser. No. 28R-35001 THRU 28R-35820, 28R-7135001 THRU 28R-7635545
- PA-28R-201 Ser. No. 28R-7737002 THRU 28R-7837317, 2837001 THRU 2837061, 2844001 & UP
- PA-28R-201T Ser. No. 28R-7703001 THRU 28R-7803373, 2803001 THRU 2803012
- PA-28RT-201 Ser. No. 28R-7918001 THRU 28R-8218026

THE NEW PIPER AIRCRAFT, INC.
VERO BEACH, FLORIDA

KIT ~ ELECTRICAL
CONTACTOR REPLACEMENT

KIT NO: 767-390 THRU 767-396,
767-399, 767-581

SHT. 12
OF 15

DWG. NO.

88371

REV.

J

SECTION IV: INSTALLATION INSTRUCTIONS (continued)

1.2.b. Continued

- PA-28RT-201T Ser. No. 28R-7931001 THRU 28R-8631005, 2831001 THRU 2831038
- PA-30 Ser. No. 30-2 THRU 30-2000
- Ⓒ PA-31/31-300 Ser. No. 31-2 THRU 31-861, 31-7300901 THRU 31-7400989, 31-7400991 THRU 31-7401268
- Ⓒ PA-31/31-325 Ser. No. 31-7400990, 31-7512001 THRU 31-8312019
- PA-31-350 Ser. No. 31-5002 THRU 31-5004, 31-7305005 THRU 31-8452024
- PA-31-350 (T-1020) Ser. No. 31-8253001 THRU 31-8553002
- PA-31P Ser. No. 31P-1 THRU 31P-80, 31P-7300110 THRU 31P-7400230, 31P-7530001 THRU 31P-7730012
- PA-32-260 Ser. No. 32-01, 32-1 THRU 32-14, 32-16 THRU 32-20, 32-22 THRU 32-1297, 32-7100001 THRU 32-7800008
- PA-32-300 Ser. No. 32-15, 32-21, 32-40000 THRU 32-40974, 32-7140001 THRU 32-7940290
- PA-32-301 Ser. No. 32-8006002 THRU 32-8606023, 3206002 THRU 3206088
- PA-32-301T Ser. No. 32-8024001 THRU 32-8424002
- PA-32-301 FT Ser. No. 3232001 & UP
- PA-32-301 XTC Ser. No. 3255001 & UP
- PA-32R-300 Ser. No. 32R-7680001 THRU 32R-7880068
- PA-32R-301 (14 VOLT) Ser. No. 32R-8013001 THRU 32R-8613006, 3213001 THRU 3213041
- PA-32R-301 Ser. No. 3213042 THRU 3213103, 3246001 & UP
- PA-32R-301T Ser. No. 32R-8029001 THRU 32R-8629008, 3229001 THRU 3229003
- PA-32R-301T Ser. No. 3257001 & UP
- PA-32RT-300 Ser. No. 32R-7885001 THRU 32R-7985105
- PA-34-200 Ser. No. 34-7250001 THRU 34-7450220
- PA-34-200T Ser. No. 34-7570001 THRU 34-8170092
- PA-34-220T (14 VOLT) Ser. No. 34-8133001 THRU 34-8633031, 3433001 THRU 3433172
- PA-34-220T (28 VOLT) Ser. No. 3448001 THRU 3448035
- PA-34-220T Ser. No. 3448038 THRU 3448079, 3447001 THRU 3447029
- PA-34-220T Ser. No. 3449001 & UP
- PA-36-285/300/375 Ser. No. 36-736001 THRU 36-8160023, 36-7802001 THRU 36-8320025
- PA-38-112 Ser. No. 38-78A0001 THRU 38-82A0122
- PA-44-180 Ser. No. 44-7995001 THRU 44-8195020, 4495001 THRU 4495013, 4496001 & UP
- Ⓒ PA-44-180T Ser. No. 44-8107001 THRU 44-8207020
- PA-46-310P Ser. No. 46-8408001 THRU 46-8608067, 4608001 THRU 4608140
- PA-46-350P Ser. No. 4622001 THRU 4622200, 4636001 & UP
- PA-46R-350T Ser. No. 4692001 & UP

THE NEW PIPER AIRCRAFT, INC. VERO BEACH, FLORIDA		KIT ~ ELECTRICAL CONTACTOR REPLACEMENT	
KIT NO: 767-390 THRU 767-396, 767-399, 767-581	SHT. 13 OF 15	DWG. NO. 88371	REV. J

SECTION IV: INSTALLATION INSTRUCTIONS (continued)

NOTE:

If the existing contactor installation includes a diode assembly installed between the A+ terminal on the contactor and the airframe ground, the diode must be reinstalled on the replacement contactor. Confirm that ID band (cathode) on the diode is towards the A+ terminal.

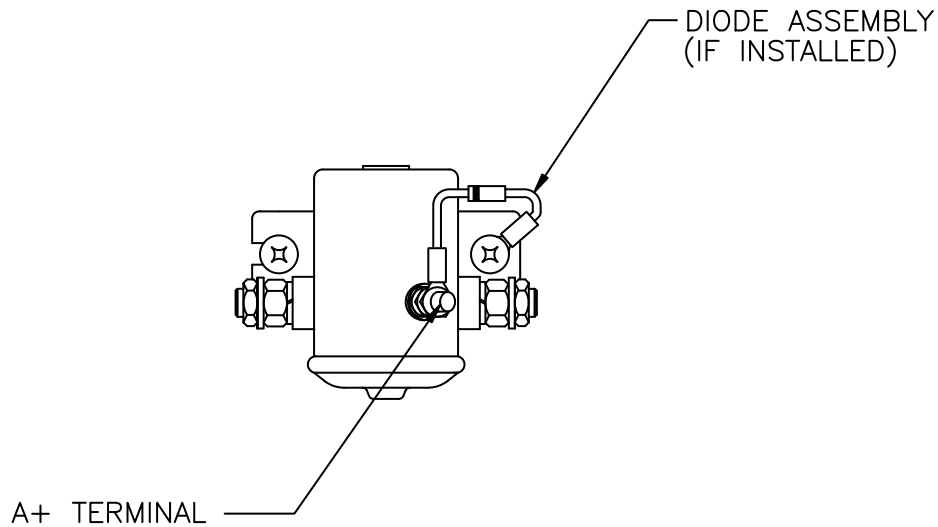

CONTACTOR INSTALLATION (OLD CONTACTORS)

VIEW B

THE NEW PIPER AIRCRAFT, INC. VERO BEACH, FLORIDA		KIT ~ ELECTRICAL CONTACTOR REPLACEMENT	
KIT NO: 767-390 THRU 767-396, 767-399, 767-581	SHT. 14 OF 15	DWG. NO. 88371	REV. J

SECTION IV: INSTALLATION INSTRUCTIONS (continued)

NOTE:

If the existing contactor installation includes a diode assembly installed between the A+ terminal on the contactor and the airframe ground, the diode must be reinstalled on the replacement contactor. Confirm that ID band (cathode) on the diode is towards the A+ terminal.

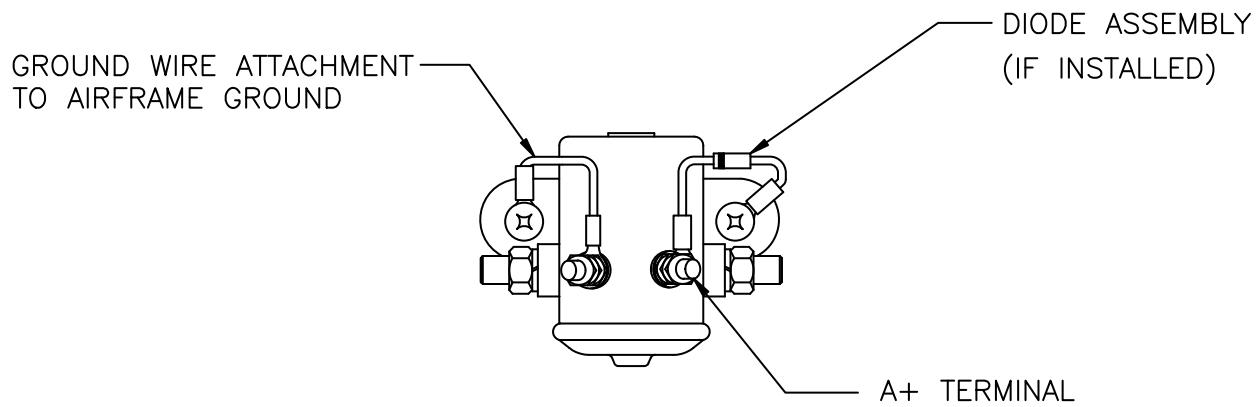

CONTACTOR INSTALLATION (WHITE RODGERS)

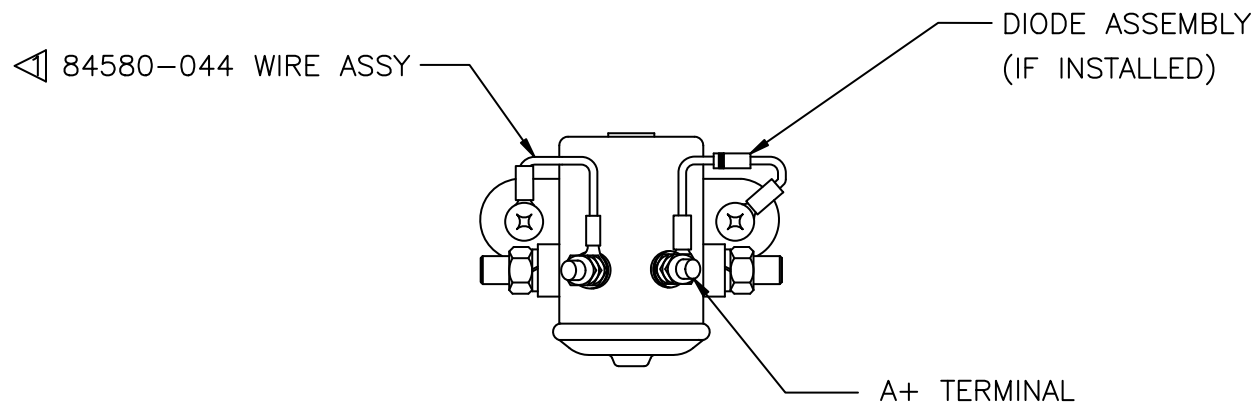

Ⓔ CONTACTOR INSTALLATION (LAMAR)

VIEW B (CONTINUED)

THE NEW PIPER AIRCRAFT, INC. VERO BEACH, FLORIDA		KIT ~ ELECTRICAL CONTACTOR REPLACEMENT	
KIT NO: 767-390 THRU 767-396, 767-399, 767-581	SHT. 15 OF 15	DWG. NO. 88371	REV. J