



Piper Aircraft, Inc.
2926 Piper Drive
Vero Beach, FL, U.S.A. 32960

SERVICE NO. 1355 BULLETIN

PIPER CONSIDERS COMPLIANCE MANDATORY

Date: February 25, 2022

(S)(M)

SUBJECT:

TEE BAR ASSEMBLY INSPECTION

MODELS AFFECTED:

PA-28-140 Cherokee

PA-28-150/-160 Cherokee
PA-28-180 Cherokee

PA-28-235 Cherokee Pathfinder

PA-28-236 Dakota

PA-28-151 Warrior
PA-28-161 Cadet
PA-28-161 Warrior II

PA-28-161 Warrior III
PA-28-180 Archer
PA-28-181 Archer II

PA-28-181 Archer III

PA-28-181 Piper Pilot 100i
PA-28-201T Turbo Dakota
PA-28R-180 Arrow

PA-28R-200 Arrow

PA-28R-200 Arrow II
PA-28R-201 Arrow III

PA-28R-201T Turbo Arrow III

PA-28RT-201 Arrow IV
PA-28RT-201T Turbo Arrow IV

SERIAL NUMBERS AFFECTED:

28-20001 through 28-26946; 28-7125001 through 28-7725290

28-1 through 28-4377; 28-1760A

28E-13; 28-03; 28-671 through 28-5859; 28-7105001 through 28-7205318

28-03; 28E-11; 28-10001 through 28-11378; 28-7110001 through 28-7710089

28-7911001 through 28-8611008; 2811001 through 2811050

28-7415001 through 28-7715314

2841001 through 2841365

28-7716001 through 28-8216300; 28-8316001 through 28-8616057; 2816001 through 2816109

2816110 through 2816119; 2842001 through 2842420

28-E13; 28-7305001 through 28-7505261

28-7690001 through 28-8690056; 28-8690061, 28-8690062; 2890001 through 2890205

2890206 through 2890231; 2843001 through 2843949; 2881001 through 2881481

28020001 through 28020024

28-7921001 through 28-7921095

28R-30002 through 28R-31270; 28R-7130001 through 28R-7130013

28R-35001 through 28R-35820; 28R-7135001 through 28R-7135229

28R-7235001 through 28R-7635545

28R-7737002 through 28R-7837317; 2837001 through 2837061; 2844001 through 2844185

28R-7703001 through 28R-7803374; 2803001 through 2803012

28R-7918001 through 28R-8218026

28R-7931001 through 28R-8631005; 2831001 through 2831038

ATA/JASC: 2701

(OVER)

PA-32-260 Cherokee Six	32-03; 32-04; 32-1 through 32-1297; 32-7100001 through 32-7800008
PA-32-300 Cherokee Six 300	32-15; 32-21; 32-40000 through 32-40974; 32-7140001 through 32-7940290
PA-32R-300 Lance	32R-7680001 through 32R-7880068
PA-32RT-300 Lance II	32R-7885002 through 32R-7985106
PA-32RT-300T Turbo Lance II	32R-7787001; 32R-7887002 through 32R-7987126
PA-32R-301 Saratoga SP	32R-8013001 through 32R-8613006; 3213001 through 3213028; 3213030 through 3213041
PA-32R-301 Saratoga II HP	3213029; 3213042 through 3213103; 3246001 through 3246244
PA-32R-301T Turbo Saratoga SP	32R-8029001 through 32R-8629008; 3229001 through 3229003
PA-32-301 Saratoga	32-8006002 through 32-8606023; 3206001 through 3206019; 3206042 through 3206044; 3206047; 3206050 through 3206055; 3206060
PA-32-301T Turbo Saratoga	32-8024001 through 32-8424002
PA-32R-301T Saratoga II TC	3257001 through 3257483
PA-32-301FT Piper 6X	3232001 through 3232074
PA-32-301XTC Piper 6XT	3255001 through 3255027; 3255051
PA-34-200 Seneca	34-E4; 34-7250001 through 34-7450220
PA-34-200T Seneca II	34-7570001 through 34-8170092
PA-34-220T Seneca III	34-8133001 through 34-8633031; 3433001 through 3433172; 3448001 through 3448037
PA-34-220T Seneca IV	3448038 through 3448079; 3447001 through 3447029
PA-34-220T Seneca V	3449001 through 3449514
PA-44-180 Seminole	44-7995001 through 44-8195026; 4495001 through 4495013; 4496001 through 4496524
PA-44-180T Seminole	44-8107001 through 44-8207020

COMPLIANCE TIME:**Part I. Inspection**

For aircraft with 3,500 or more hours time in service (TIS), initial compliance is to occur within the next 100 hours TIS. Thereafter, a recurring inspection shall occur every 100 hours TIS, until compliance with Part II has been accomplished.

NOTE: Modification of the tee bar assembly as described in Part II, or installation of a replacement tee bar assembly with the features shown in Figure 1, Detail B, will relieve the recurring inspection requirement in Part I.

Part II. Replacement

Compliance is to occur, if cracks are found, prior to next flight. Otherwise, at owner/operator discretion, compliance with Part II will relieve the recurring inspection requirements described in Part I.

APPROVAL:

The engineering aspects of this service document have been shown to comply with the applicable Federal Aviation Regulations and are FAA approved.

PURPOSE:

A review of service history reveals that cracks may develop in the tee bar assembly of the affected aircraft. This service bulletin provides instructions for the recurring inspection of the tee bar assembly for cracks. Replacement of the installed tee bar weldment assembly with the applicable new tee bar weldment assembly specified in Table 1 will eliminate the need for a recurring inspection.

INSTRUCTIONS:NOTES:

- The term weldment is defined as “a unit formed by welding together an assembly of pieces.” A tee bar weldment is the welded metal assembly that is a portion of the complete tee bar assembly (see Figure 1).
- Temporary removal of some interior components and/or access panels may be required in order to accomplish the instructions described in this service bulletin.
- Prior to inspection, wipe surfaces clean using a soft cloth dampened with isopropyl alcohol, mineral spirits, naphtha, or other suitable cleaning agent.
- The inspections described in this service bulletin shall be accomplished using a 10X magnifier, a mirror and a suitable light source or other equipment capable of providing equal or better resolution.

Part I. Inspection

WARNING: FLIGHT WITH KNOWN CRACKS IN THE AIRCRAFT STRUCTURE IS NOT ALLOWED. AN AIRPLANE WITH A CRACK IN STRUCTURE MAY NO LONGER MEET ITS TYPE DESIGN AND MAY NO LONGER POSSESS ITS TYPE DESIGN STRENGTH. ANY CRACKS DISCOVERED IN THE AIRCRAFT STRUCTURE MUST BE REPAIRED PRIOR TO THE NEXT FLIGHT.

1. Gain visual access to the top center portion of the tee bar assembly, as shown in Figure 1. Identify the configuration of the tee bar weldment assembly.
 - If the local area conforms to Figure 1, Detail A, then recurring inspections are required. Proceed to Step 2.
 - If the local area conforms to Figure 1, Detail B, then the tee bar assembly has already been modified in accordance with Part II, or has been replaced with a tee bar assembly containing the required features (i.e., gusset). No recurring inspections are required. Proceed to Part II, Step 2.
2. Examine the area shown in Detail A for cracks, with special emphasis on welded joints.

NOTE: For inspection and paint guidance, refer to FAA Advisory Circular AC 43.13-1B, “Acceptable Methods, Techniques, and Practices – Aircraft Inspection and Repair.” This free document is available for download from the FAA at https://www.faa.gov/regulations_policies/advisory_circulars/.

- a. If the paint is cracked, chipped or peeled in the vicinity of the inspection areas, or if there is evidence of corrosion (such as staining or blistering), then a fluorescent penetrant inspection is required as described in Step b, below. Prepare the surface by removing the paint using Cee-Bee A-202 paint stripper, or an equivalent. Wipe off any residue, in the areas where the paint was removed, with isopropyl alcohol.

NOTE: Paint must be removed using chemical processes only. The use of abrasives or other mechanical methods to remove the paint will hide the existence of any discontinuities, making an accurate inspection impossible.

NOTE: Follow the paint stripper manufacturer’s instructions, including the use of proper ventilation, and/or the use of personal protective equipment (PPE), as applicable.

- b. Perform a fluorescent dye penetrant inspection per FAA Advisory Circular AC 43.13-1B, Chapter 5, Section 5.
 - If any cracks are discovered, then the tee bar weldment must be replaced prior to next flight. Proceed to Part II.
 - If no cracks are discovered, apply primer and topcoat to bare metal, per the applicable Piper Airplane Maintenance Manual (AMM) or Service Manual (SM) and FAA Advisory Circular AC 43.13-1B, Chapter 6. Proceed to Step 3.
3. Perform a functional check on any systems that were disturbed during this inspection.
 4. Make a logbook entry documenting compliance with Part I this service bulletin.

Part II. Replacement

1. Order and install one (1) each, of the applicable tee bar weldment assembly, per Table 1.
2. To replace the tee bar weldment assembly, first, in accordance with Section 27-10-00 of the applicable Piper AMM or Section V of the applicable SM, remove the control wheels and the control column tee bar assembly from the aircraft.
3. Remove all sprockets, the control wheel columns, and hardware (bolts, nuts, washers) from the tee bar weldment assembly and retain them for reinstallation. Replace any hardware on condition.
4. Assemble the control wheel tee bar assembly (refer to Figure 2): Install the sprockets, control wheel columns, and hardware, which were removed from the original weldment assembly in the previous step, onto the replacement tee bar weldment assembly.
5. Reinstall the control column tee bar assembly and control wheel columns, in accordance with Section 27-10-00 of the applicable Piper AMM or Section V of the applicable SM. If necessary, so that there is no greater than 0.010 in. of free play (relative motion) and no drag exists between the control columns and sprocket assemblies, add Brass Shims, Piper P/N 62833-152, no more than two (2) per side, as shown in Figure 3.
6. Reinstall the control wheels in accordance with Section 27-10-00 of the applicable Piper AMM or Section V of the applicable SM.
7. Perform a functional check on any systems that were disturbed to gain access for, and during, this modification.
8. Make a logbook entry documenting compliance with Part II this service bulletin.

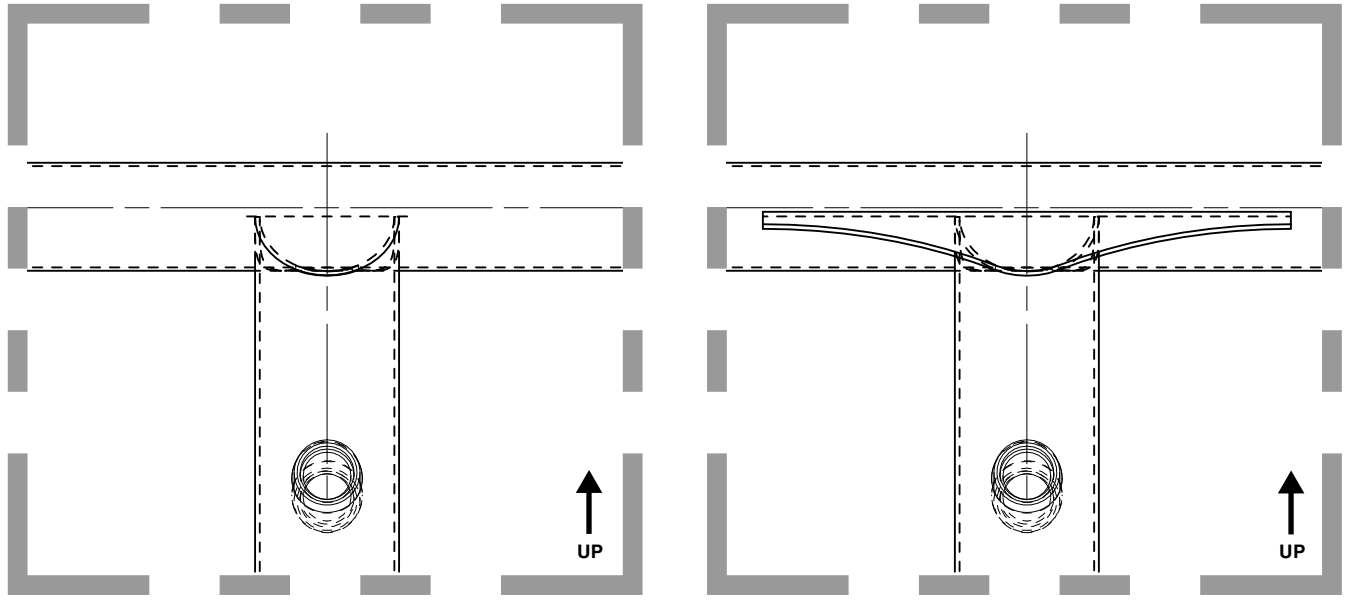

DETAIL A
LOOKING FORWARD AT
CONTROL COLUMN TEE BAR WELDMENT
WITHOUT GUSSET

DETAIL B
LOOKING FORWARD AT
CONTROL COLUMN TEE BAR WELDMENT
WITH GUSSET

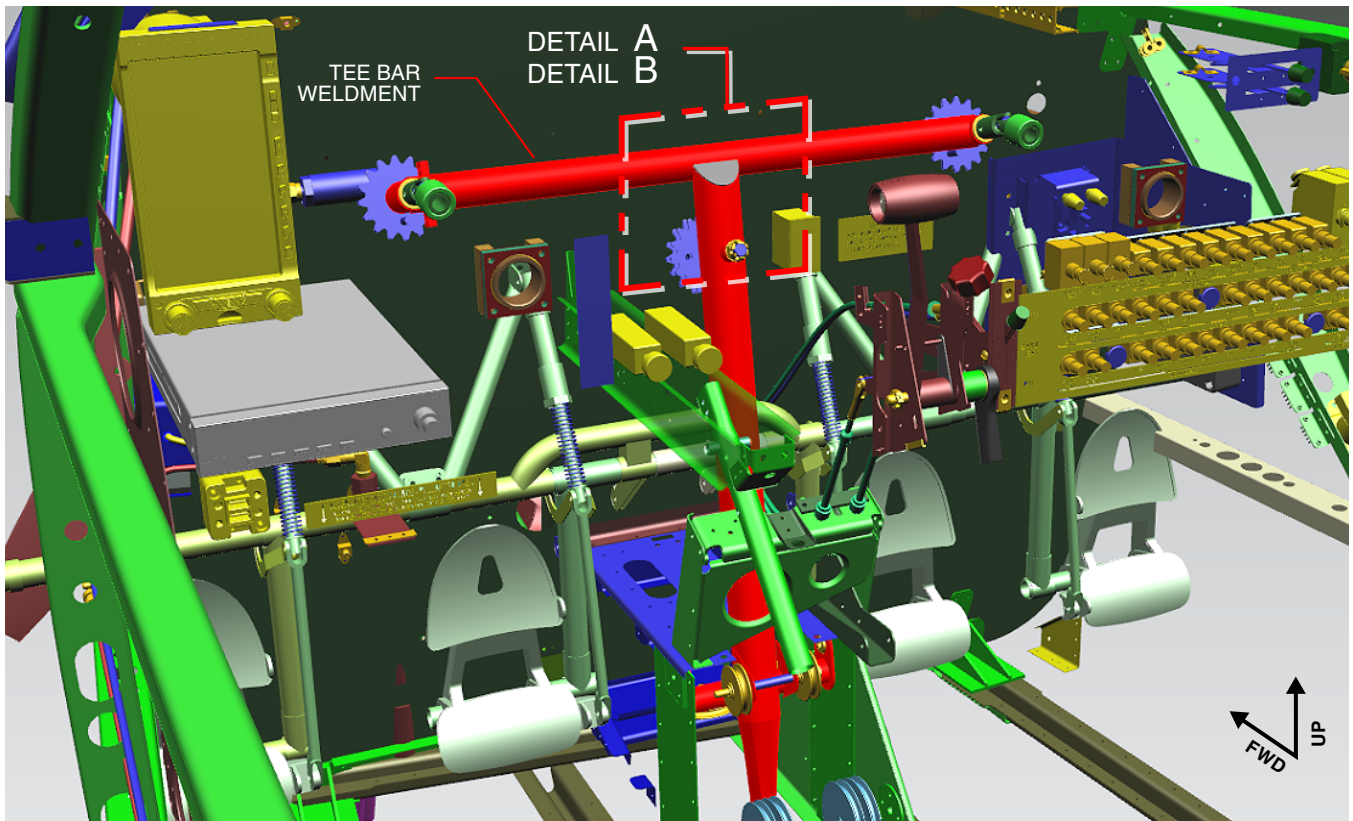

TEE BAR ASSEMBLY
LOOKING FORWARD
SOME COMPONENTS REMOVED FOR CLARITY

Figure 1
Tee Bar Assembly – Weldment

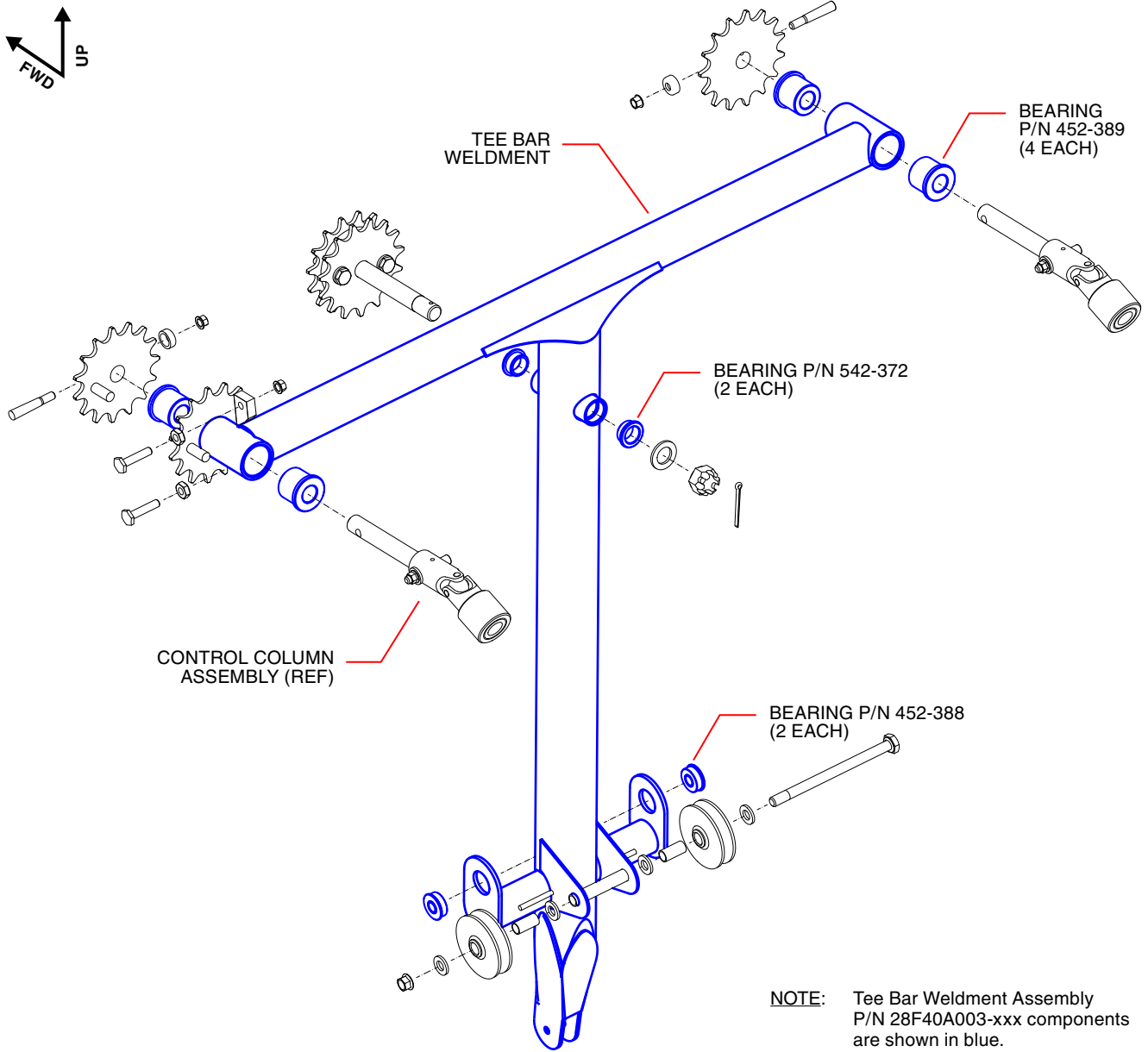

TEE BAR ASSEMBLY

P/N 28F40A003-001 SHOWN (OTHERS ARE SIMILAR)

EXPLODED VIEW (TYPICAL)

SOME COMPONENTS REMOVED FOR CLARITY

Figure 2

Tee Bar Assembly – Weldment Assembly Installation

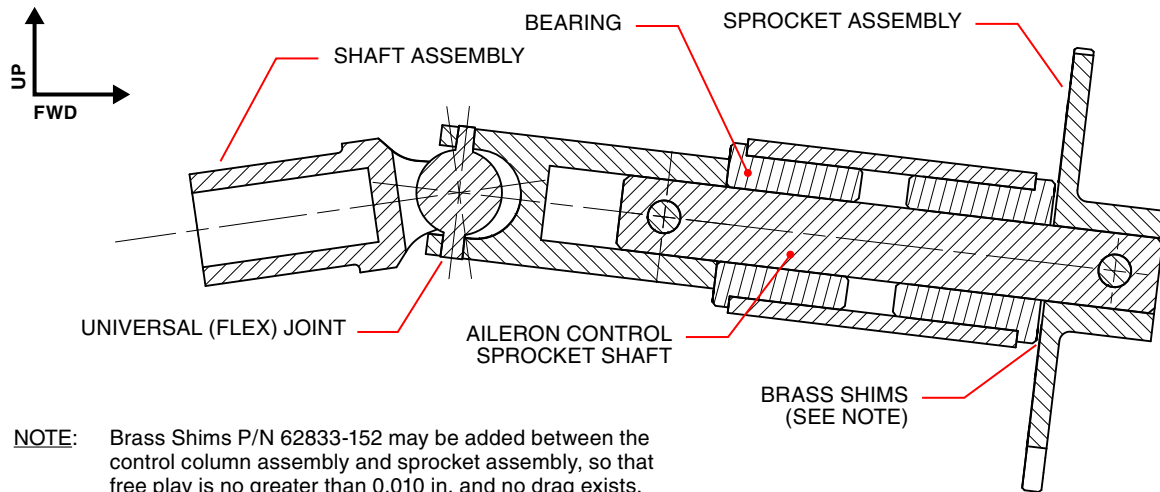

CONTROL COLUMN ASSEMBLY – TYPICAL
LOOKING OUTBOARD
PILOT SIDE SHOWN (COPILOT SIDE SIMILAR)

Figure 3
Brass Shim P/N 62833-152 Installation Location

TABLE 1
TEE BAR WELDMENT ASSEMBLY REPLACEMENT PARTS

MODEL NUMBER	EFFECTIVITY	ASSEMBLY P/N 28F40A003 "DASH"
PA-28-140	28-20002 through 28-21445	702
	28-21446 through 28-21845, 28-21931 through 28-21934, 28-23242 through 28-26956; 28-7125001 through 28-7725290	703
	28-21846 through 28-21930, 28-21935 through 28-23241	707
PA-28-150	28-1231 through 28-2977	702
	28-2978 through 28-3377, 28-4118 through 28-4377	703
	28-1 through 28-1230	705
	28-3378 through 28-4117	707
PA-28-151	28-7415001 through 28-7715314	703
PA-28-160	28-1231 through 28-2977	702
	28-2978 through 28-3377, 28-4118 through 28-4377	703
	28-1 through 28-1230	705
	28-3378 through 28-4117	707
PA-28-161	28-7716002 through 28-8616057; 2816001 through 2816119; 2841001 through 2841365; 2842001 through 2842420	703
PA-28-180	28-1231 through 28-2977	702
	28-E13; 28-2978 through 28-3377; 28-4118 through 28-5869; 28-7102001 through 28-7305611; 28-7405001 through 28-7505261	703
	28-671 through 28-1230	705
	28-3378 through 28-4117	707
PA-28-181 Archer III	28-7690001 through 28-8690056; 2890001 through 2890231; 2843001 through 2843701, 2843703 through 2843942; 2881001 through 2881481	703
PA-28-181 Piper Pilot 100i	28020001 through 28020024	703
PA-28-201T	28-7921001 through 28-7921095	703
PA-28-235	28-10002 through 28-10719	702
	28-E11; 28-10944 through 28-11393; 28-7110001 through 28-7710089	703
	28-10720 through 28-10943	707
PA-28-236	28-7911001 through 28-8611008; 2811001 through 2811050	703
PA-28R-180	28R-30005 through 28R-30481, 28R-30483 through 28R-31279; 28R-7130001 through 28R-7130029	706
PA-28R-200	28R-30482; 28R,35001 through 28R-35830; 28R-7135001 through 28R-7635545	706
PA-28R-201	28R-7737002 through 28R-7837317; 2837001 through 2837061; 2844001 through 28444185	706
PA-28R-201T	28R-7703001 through 28R-7803372; 2803001 through 2803015	706
PA-28RT-201	28R-7918001 through 28R-8218026	706
PA-28RT-201T	28R-7931001 through 28R-8631004; 2831001 through 2831038	706

TABLE 1 (CONT'D)
TEE BAR WELDMENT ASSEMBLY REPLACEMENT PARTS

MODEL NUMBER	EFFECTIVITY	ASSEMBLY P/N 28F40A003 "DASH"
PA-32-260	32-1 through 32-300	701
	32-301 through 32-600	704
	32-601 through 32-960	708
	32-961 through 32-1320; 32-7100001 through 32-7300076; 32-7400001 through 32-7800008	704
PA-32-300	32-40000 through 32-40415	708
	32-40416 through 32-41018; 32-7140001 through 32-7940290	704
PA-32-301	32-8006001 through 32-8606023; 3206001 through 3206098	704
PA-32-301FT	3232001 through 3232074	704
PA-32-301T	32-8024001 through 32-8424002	704
PA-32-301XTC	3255001 through 3255051	704
PA-32R-300	32R-7680001 through 32R-7880068	704
PA-32R-301	32R-8013001 through 32R-8613006; 3213001 through 3213041	704
PA-32R-301HP	3213029, 3213042 through 3213103; 3246001 through 3246244	704
PA-32R-301T	32R-8029001 through 32R-8629008; 3229001 through 3229003	704
PA-32R-301TC	3257001 through 3257493	704
PA-32RT-300	32R-7885002 through 32R-7985106	704
PA-32RT-300T	32R-7787001, 32R-7887002 through 32R-7987126	704
PA-34-200	34-7250001 through 34-7450220	704
PA-34-200T	34-7570002 through 34-8170092	704
PA-34-220T (III, IV, V)	34-8133001 through 34-8633031; 3447001 through 3447029; 3448001 through 3448079; 3449001 through 3449310, 3449312 through 3449322, 3449324, 3449325, 3449410, 3449415 through 3449419, 3449421 through 3449458, 3449460 through 3449466	709
PA-34-220T (V)	3449311, 3449323, 3449326 through 3449409, 3449411 through 3449414, 3449420, 3449459, 3449467 through 3449514	710
PA-44-180	44-7995001 through 44-8195026; 4495001 through 4495013; 4496001 through 4496524	703
PA-44-180T	44-8107001 through 44-8207020	703

MATERIAL REQUIRED:

On condition, per aircraft:

- One (1) each, the applicable Weldment Assembly, per Table 1
- Up to four (4) each, Brass Shim (0.005 in.), Piper P/N 62833-152 (discard any unused)
- 12 each, Locking Clip Turnbuckle, Piper P/N 554-979 (MS21256-1)

AVAILABILITY OF PARTS:

Your Piper Approved Service Center – Weldment Assembly and Brass Shims;
Clip Turnbuckles – procure locally

EFFECTIVITY DATE:

This service bulletin is effective upon receipt.

SUMMARY:

Please contact your Piper Approved Service Center to make arrangements for compliance with this service bulletin in accordance with the compliance time indicated.

NOTE: Please notify the factory of any address/ownership corrections. Changes should include aircraft model, serial number, and current owner's name and address.

Corrections and/or changes should be directed to:

PIPER AIRCRAFT, INC.
Attn: Customer Service
2926 Piper Drive
Vero Beach, FL 32960

or:

CustomerService@piper.com

Please include in subject line: "Aircraft ownership update"