



**Piper Aircraft, Inc.**  
 2926 Piper Drive  
 Vero Beach, FL, U.S.A. 32960

# SERVICE NO. 1342A BULLETIN

## PIPER CONSIDERS COMPLIANCE MANDATORY

Date: November 2, 2021

(S)

Service Bulletin (SB) 1342A supersedes SB 1342 in its entirety. Aircraft that were previously made compliant with SB 1342 are in compliance with SB 1342A.

**SUBJECT:**

**STABILATOR FITTING INSPECTION**

**REASON FOR REVISION:**

SB 1342A revises the effectivities for PA-28-181 Archer III model, in Group A and Group B.

**MODELS AFFECTED:**

**SERIAL NUMBERS AFFECTED:**

**Group A**

PA-28-181 Archer III

2881001 through 2881175, 2881177 through 2881200

**Group B**

PA-28-140 Cherokee Cruiser

28-20001 through 28-26946; 28-7125001 through 28-7725290

PA-28-150/-160 Cherokee

28-03; 28-1 through 28-4377 and 28-1760A

PA-28-180 Cherokee

28-03; 28-671 through 28-5859; 28-7105001 through 28-7205318

PA-28-235 Cherokee Pathfinder

28-10001 through 28-11378; 28-7110001 through 28-7210023; 28E-11; 28-7310001 through 28-7710089

PA-28-236 Dakota

28-7911001 through 28-8611008; 2811001 through 2811050

PA-28-151 Warrior

28-7415001 through 28-7715314

PA-28-161 Cadet

2841001 through 2841365

PA-28-161 Warrior II

28-7716001 through 28-8216300; 28-8316001 through 28-8616057; 2816001 through 2816109

PA-28-161 Warrior III

2816110 through 2816119; 2842001 and up

PA-28-180 Archer

28-E13; 28-7305001 through 28-7505260

PA-28-181 Archer II

28-7690001 through 28-8690056; 28-8690061; 28-8690062; 2890001 through 2890205

PA-28-181 Archer III

2890206 through 2890231; 2843001 through 2843949

PA-28-201T Turbo Dakota

28-7921001 through 28-7921095

PA-28R-180 Arrow

28R-30002 through 28R-31270; 28R-7130001 through 28R-7130013

PA-28R-200 Arrow/Arrow II

28R-35001 through 28R-35820; 28R-7135001 through 28R-7635545

ATA/JASC: 5510

(OVER)

PA-28R-201 Arrow III	28R-7737002 through 28R-7837317; 2837001 through 2837061; 2844001 and up
PA-28R-201T Turbo Arrow III	28R-7703001 through 28R-7803374; 2803001 through 2803015
PA-32-260 Cherokee Six	32-03, 32-04; 32-1 through 32-1297; 32-7100001 through 32-7800008
PA-32-300 Cherokee Six	32-15, 32-21; 32-40000 through 32-40974; 32-7140001 through 32-7940290
PA-32R-300 Lance	32R-7680001 through 32R-7880068
PA-32-301 Saratoga	32-8006002 through 32-8606023; 3206001 through 3206088
PA-32-301T Turbo Saratoga	32-8024001 through 32-8424002
PA-32R-301 Saratoga SP	32R-8013001 through 32R-8613006; 3213001 through 3213028; 3213030 through 3213041
PA-32R-301 Saratoga II HP	3213029, 3213042 through 3213103; 3246001 through 3246244
PA-32R-301T Turbo Saratoga SP	32R-8029001 through 32R-8629008; 3229001 through 3229003
PA-32R-301T Saratoga II TC	3257001 through 3257493
PA-32-301FT Piper 6X	3232001 through 3232074
PA-32-301XTC Piper 6XT	3255001 through 3255051

**COMPLIANCE TIME:** To coincide with the next regularly scheduled maintenance event, but not to exceed the next 100 hours time in service

**APPROVAL:** The engineering aspects of this service document have been shown to comply with the applicable Federal Aviation Regulations and are FAA approved.

**PURPOSE:** By design, the stabilator pivots on two bearings installed into two empennage-mounted Stabilator Attachment Fitting Assemblies, Piper part number (P/N) 62645-004. Integral to these fittings are tapped holes, which receive bolts that are used to adjust the upper and lower travel limits of the stabilator.

Piper P/N 62645-004 is designed by Piper and fabricated by a supplier. The supplier has notified Piper that a quantity of these fittings were manufactured and delivered to Piper with upper tapped holes that were mislocated. These nonconforming fittings may have been installed on some of the affected airplanes. This service bulletin mandates a one-time inspection of the fittings on the affected airplanes and, on condition, the replacement of one or both fittings.

**INSTRUCTIONS:**

NOTE: The instructions that follow apply to both left and right sides of the airplane.

NOTE: The temporary removal of some components and/or access panels may be required to accomplish the instructions described in this service bulletin.

1. Take the following action, depending upon model group:
  - For airplanes listed in Group A, proceed to Step 2.
  - For airplanes listed in Group B, examine maintenance records to determine if any replacement Stabilator Attachment Fitting Assembly, Piper part number (P/N) 62645-004 was ordered between April 17 and July 30, 2019, and installed on the aircraft.
    - If so, or if maintenance records for the specified time frame are not available, proceed to Step 2.
    - If not, proceed to Step 6.
2. Gain visual access to both Stabilator Attachment Fitting Assemblies, Piper P/N 62645-004.
3. Compare the installed configuration to Figure 1, Views B–B and C–C.

If the Bolt, P/N 553-266, protrudes past the edge of the Fitting, P/N 63563-000, as shown in View C–C, then measure the distance from the edge of the fitting to the outermost portion of the bolt, as shown in View D–D.

  - **Does not conform to type design:** If the measured distance, per View D–D, is 0.10 inch or greater, then the Stabilator Attachment Fitting Assembly, P/N 62645-004, must be replaced. Proceed to Step 4.
  - **Conforms to type design:** Any fitting that matches View B–B conforms to type design, so replacement is not required. If the measured distance, per View D–D, is less than 0.10 inch, then replacement is not required. Proceed to Step 6.
4. Order and install one or two per airplane, as required, Stabilator Attachment Fitting Assembly, P/N 62645-004.
  - a. Remove the stabilator per Chapter 55 of the applicable Piper Airplane Maintenance Manual (AMM) or Section IV of the applicable Piper Service Manual (SM).
  - b. Remove the six bolts, washers and nuts that retain the stabilator attachment fitting assemblies to be replaced. Retain the hardware, depending on condition. Replace any hardware on condition.
  - c. Remove and discard the attachment fitting assemblies.
  - d. Position for installation the new Stabilator Attachment Fitting Assembly, P/N 62645-004, and hand tighten the six bolts, washers and nuts.
  - e. Torque the nuts in a standard X-pattern to the values provided in Ch. 55 of the applicable Piper AMM or Sec. IV of the applicable Piper SM.
  - f. Reinstall the stabilator (including rigging and adjustment, as directed in the manuals) per Ch. 55 of the applicable Piper AMM or Sec. IV of the applicable Piper SM.
5. Perform a functional test on any systems that were disturbed during this inspection.
6. Make a logbook entry documenting compliance with this service bulletin.

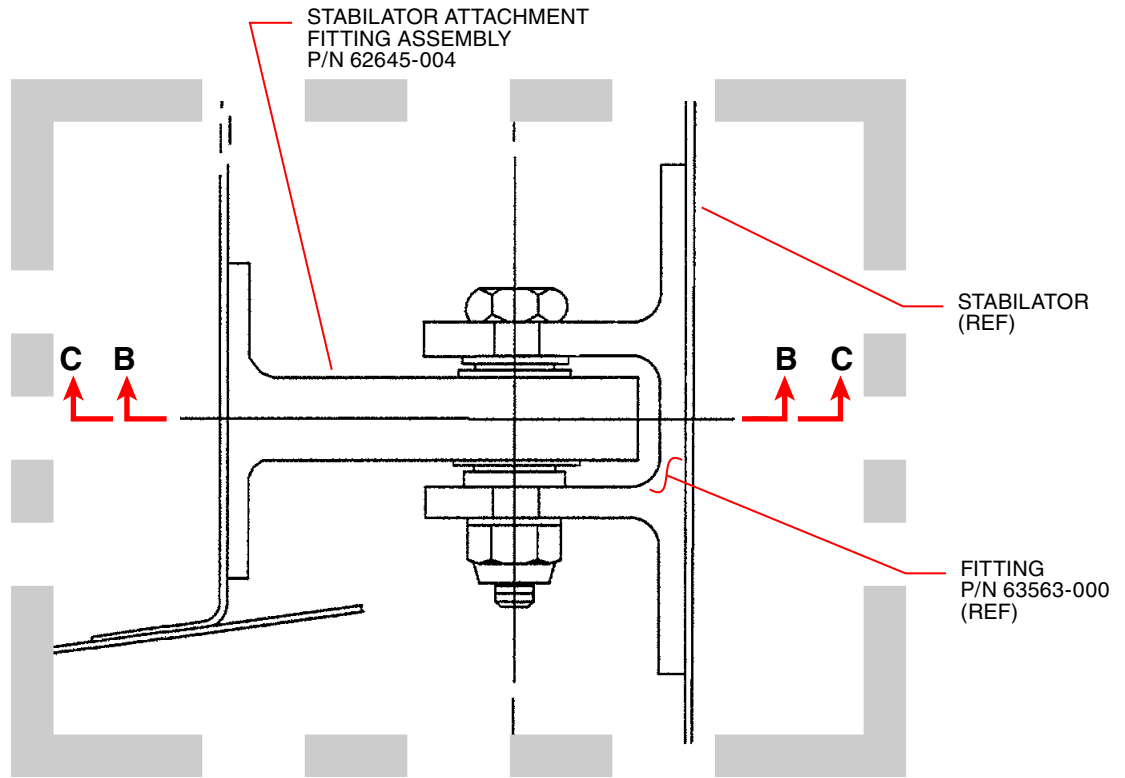

**DETAIL A**  
STABILATOR HINGE INSTALLATION

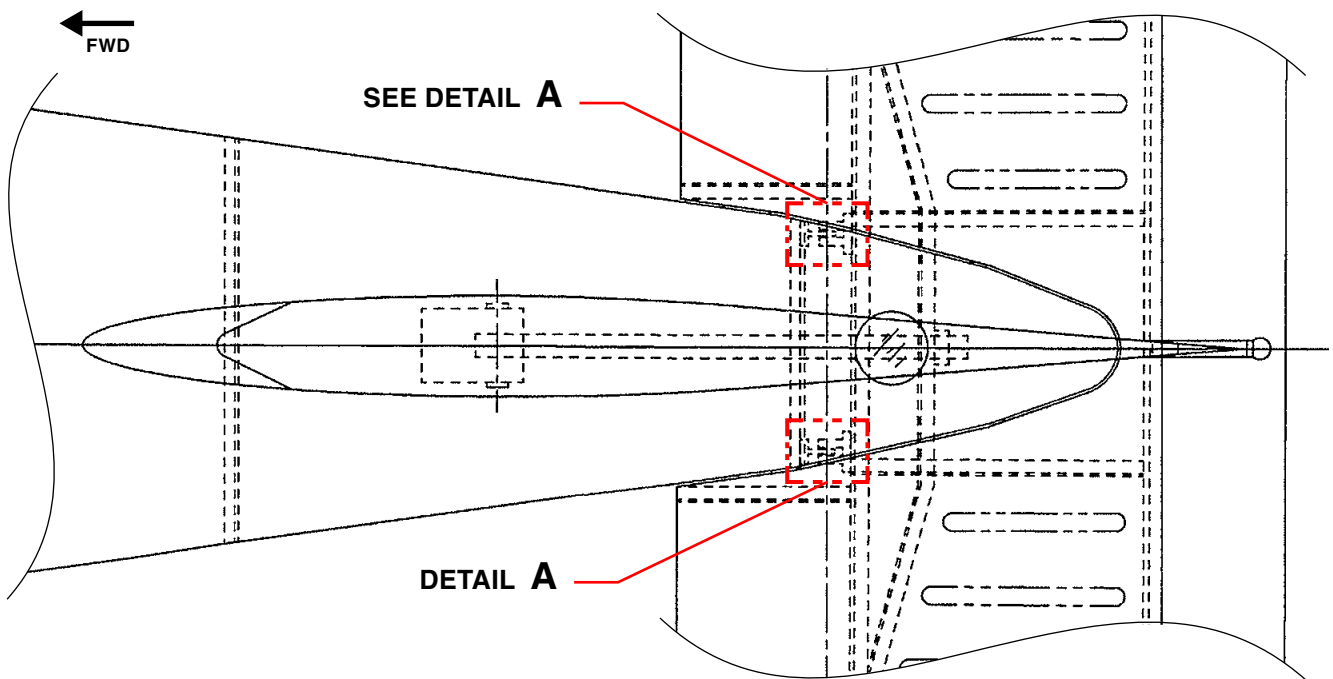

**TAIL AND STABILATOR INSTALLATION**  
(TYPICAL)  
LOOKING DOWN

**Figure 1, Sheet 1 of 3**  
Stabilator Attach Fitting Assemblies

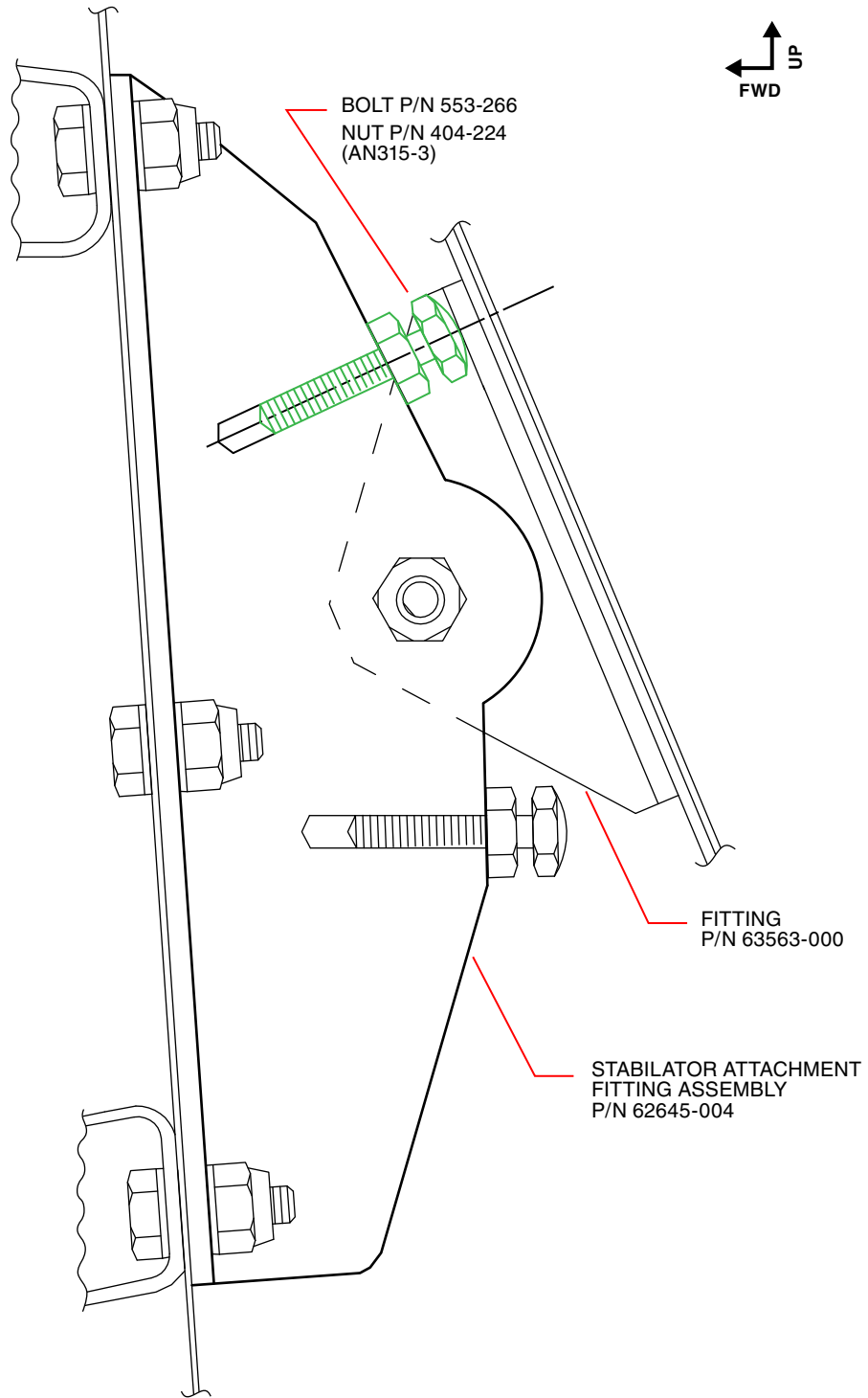

**VIEW B-B**  
**CONFORMING**  
STABILATOR ATTACHMENT FITTING INSTALLATION  
(NO REPLACEMENT IS REQUIRED)

**Figure 1, Sheet 2 of 3**  
Stabilator Attach Fitting Assemblies

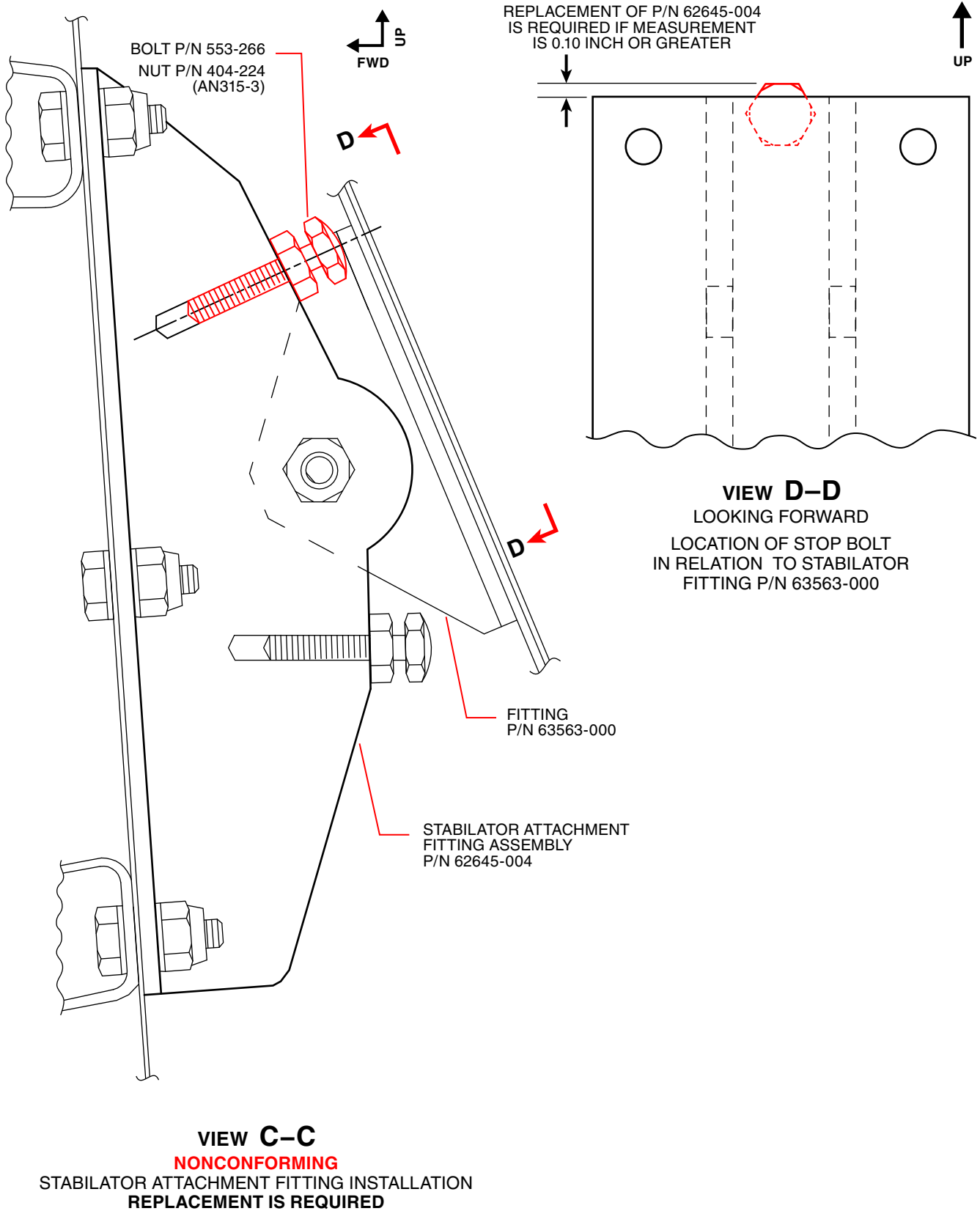

Figure 1, Sheet 3 of 3  
Stabilator Attach Fitting Assemblies

**MATERIAL REQUIRED:** Up to two (2) each, on condition, Stabilator Attachment Fitting Assembly, P/N 62645-004, per aircraft

**AVAILABILITY OF PARTS:** Your Piper Approved Service Center

**EFFECTIVITY DATE:** This service bulletin is effective upon receipt.

**SUMMARY:** Applicable factory participation is limited to new aircraft in warranty at the time of compliance. Factory participation will remain in effect for a period of time not to exceed 180 days from the date of this service bulletin.  
Please contact your Piper Approved Service Center to make arrangements for compliance with this service bulletin in accordance with the compliance time indicated.

**NOTE:** Please notify the factory of any address/ownership corrections. Changes should include aircraft model, serial number, and current owner's name and address.

Corrections and/or changes should be directed to:

PIPER AIRCRAFT, INC.  
Attn: Customer Service  
2926 Piper Drive  
Vero Beach, FL 32960

or:

CustomerService@piper.com

Please include in subject line: "Aircraft ownership update"