

SERVICE BULLETIN

Compliance Will Enhance Safety

CATEGORY 3
SB13-4C

Supersedes SB13-4B
 TECHNICAL PORTIONS
FAA APPROVED

SUBJECT: Aneroid Equipped Fuel Pumps

PURPOSE: Inspect fuel pumps for applicability; remove and replace affected units.

COMPLIANCE: Within the next fifty (50) hours of operation or the next time the fuel pump is accessed, whichever is sooner.

MODELS

AFFECTED: New and rebuilt IO360, LTSIO360, TSIO360, GTSIO520, LTSIO520, TSIO520, IO550, and TSIO550

I. BACKGROUND INFORMATION

Due to changes in a manufacturing process, a supplier has notified Continental Motors of a limited number of bellows used in aneroid equipped fuel pumps which pass acceptance testing but exhibit a potential for reduced service life.

A malfunctioning bellows will not react to differential pressure as designed, causing the fuel mixture, especially at higher power settings, to run leaner than design specifications.

CAUTION: Pilots should follow the applicable Airplane Flight Manual (AFM)/Pilot's Operating Handbook (POH) recommendations and cross-check RPM, manifold air pressure, and fuel flow/fuel pressure during the take-off run. Observations during testing have shown that fuel pressure can be restored by activating the aircraft fuel boost pump.

Characteristic symptoms associated with a faulty bellows assembly are:

- decreased fuel flow/fuel pressure
- higher than normal CHT (compared to engine specification)
- inability to adjust fuel system to meet published specifications
- minor power reduction at take-off.

II. SCOPE

All engines identified under "Model Affected" must be inspected and all fuel pumps identified in Tables 1 and 2 (beginning on page 2), manufactured between 30 Jan 2012 and 28 Jun 2012, must be REMOVED and REPLACED within the next 50-hours of operation.

ISSUED	REVISED	 P.O. Box 90 Mobile, AL 251-436-8299	PAGE NO	DOC NO	REVISION
2013/08/23	2016/11/07		1 of 8	SB13-4	C

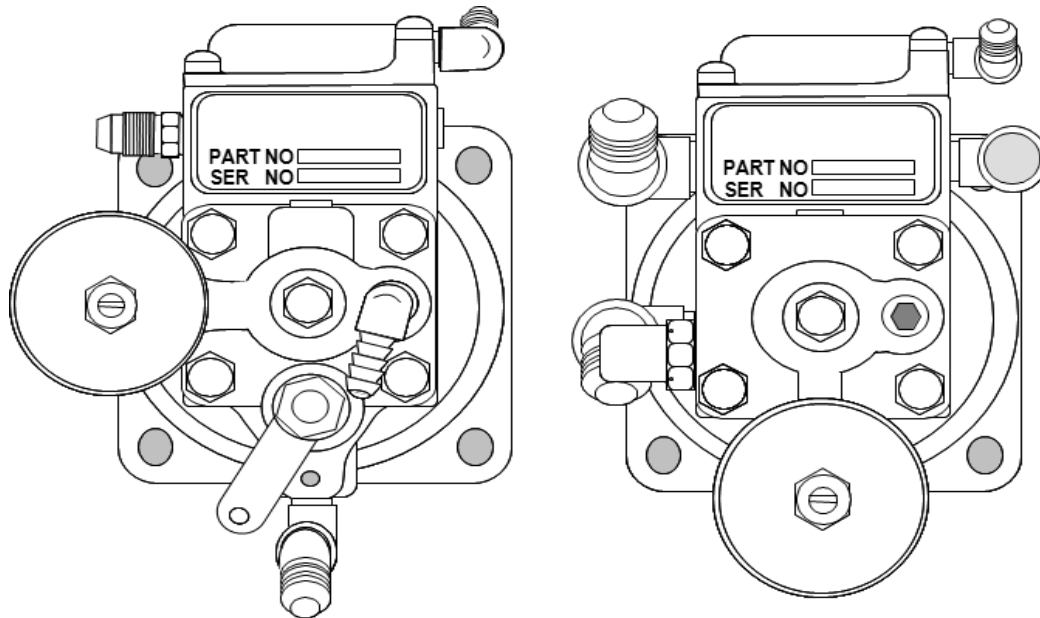

Figure 1. Identifying Part/Serial Numbers on Affected Fuel Pump

Table 1. Fuel Pumps (Sold Individually)

Fuel Pump P/N	Fuel Pump S/N	Fuel Pump P/N	Fuel Pump S/N	Fuel Pump P/N	Fuel Pump S/N
646210-25A3	B12CA156R	649368-74A4	B12CA138	R-646210-29A1	B12DA128R
646210-28A1	B12EA157	649368-74A4	B12EA007	R-646210-29A1	B12DA149
646210-28A1	B12EA156	R-646210-22A10	B12EA117R	R-646210-29A1	B12DA150R
646768-5A1	B12FA055	R-646210-22A10	B12EA116R	R-646210-30A2	B12FA080R
646768-5A2	B12DA030	R-646210-24A1	B12BA007R	R-646210-30A2	B12CA038R
649368-60A1	B12BA097	R-646210-24A1	B12FA112R	R-646211-5A1	B12FA176R
649368-60A3	B12DA052	R-646210-24A1	B12CA036R	R-646211-5A1	B12EA169R
649368-60A7	B12FA046	R-646210-24A1	B12BA008R	R-646211-5A2	B12FA169R
649368-60A7	B12EA053	R-646210-24A1	B12EA108R	R-646766-14A1	B12EA027R
649368-60A7	B12FA180	R-646210-24A1	B12CA035R	R-646766-14A1	B12EA110R
649368-60A7	B12EA055	R-646210-25A3	B12BA160R	R-646766-15A1	B12EA111R
649368-60A7	B12EA054	R-646210-25A3	B12EA129R	R-646766-15A1	B12EA193R
649368-63A1	B12EA084	R-646210-27A1	B12EA160R	R-646766-15A1	B12FA014R
649368-64A1	B12EA099	R-646210-27A1	B12EA159R	R-646766-15A1	B12FA013R
649368-68A1	B12FA002	R-646210-27A1	B12EA222R	R-646767-5A1	B12FA053R
649368-68A1	B12FA010	R-646210-27A1	B12FA067R	R-646767-5A1	B12FA052R
649368-74A1	B12CA078	R-646210-27A1	B12FA077R	R-646767-5A2	B12CA123R
649368-74A3	B12FA157	R-646210-27A1	B12FA136R	R-646767-5A2	B12EA219R
649368-74A3	B12FA158	R-646210-27A1	B12FA139R	R-646767-5A2	B12EA081R
649368-74A4	B12BA066	R-646210-27A1	B12FA155R	R-646767-5A2	B12FA160R
649368-74A4	B12FA004	R-646210-27A1	B12FA068R	R-646767-5A2	B12FA168R
649368-74A4	B12EA010	R-646210-28A1	B12BA155R	R-646767-5A2	B12EA220
649368-74A4	B12EA071	R-646210-28A1	B12EA207R	R-646767-5A2	B12FA159R
649368-74A4	B12EA008	R-646210-28A1	B12EA206R	R-646767-5A2	B12EA138R

Table 1. Fuel Pumps (Sold Individually), continued

Fuel Pump P/N	Fuel Pump S/N	Fuel Pump P/N	Fuel Pump S/N	Fuel Pump P/N	Fuel Pump S/N
R-646767-5A2	B12EA137R	R-649368-58A1	B12CA080R	R-649368-64A1	B12FA140R
R-646767-5A2	B12EA136R	R-649368-58A1	B12EA146R	R-649368-64A1	B12FA142R
R-646768-5A1	B12DA154R	R-649368-60A1	B12EA056R	R-649368-64A1	B12FA141R
R-646768-5A1	B12EA195R	R-649368-60A3	B12FA167R	R-649368-66A1	B12CA027R
R-646768-5A1	B12FA125R	R-649368-60A3	B12EA050R	R-649368-66A1	B12CA100R
R-646768-5A1	B12DA153R	R-649368-63A1	B12FA145R	R-649368-66A2	B12EA065R
R-646768-5A1	B12EA038R	R-649368-63A1	B12FA144R	R-649368-66A2	B12EA066R
R-646768-5A1	B12EA039R	R-649368-63A1	B12FA107R	R-649368-66A2	B12EA189R
R-646768-5A1	B12FA220R	R-649368-63A1	B12FA106R	R-649368-67A1	B12EA003R
R-646768-5A1	B12FA245R	R-649368-63A1	B12AA239R	R-649368-67A1	B12EA115R
R-646768-5A1	B12BA004R	R-649368-63A1	B12CA031R	R-649368-67A1	B12EA005R
R-646768-5A1	B12CA059R	R-649368-63A1	B12BA161R	R-649368-67A1	B12EA112R
R-646768-5A1	B12FA127R	R-649368-63A1	B12EA143R	R-649368-67A1	B12EA218R
R-646768-5A1	B12BA043R	R-649368-63A1	B12EA142R	R-649368-67A1	B12EA192R
R-646768-5A1	B12EA145R	R-649368-63A1	B12BA150R	R-649368-67A1	B12EA191R
R-646768-5A1	B12DA027R	R-649368-63A1	B12EA024R	R-649368-67A1	B12EA114R
R-646768-5A1	B12BA185R	R-649368-63A2	B12EA131R	R-649368-74A4	B12EA244R
R-646768-5A1	B12DA026R	R-649368-63A2	B12EA194R	R-649368-74A4	B12CA114R
R-646768-5A1	B12CA070R	R-649368-64A1	B12BA172R	R-649368-74A4	B12FA001R
R-646768-5A1	B12CA071R	R-649368-64A1	B12DA178R	R-649368-74A4	B12CA112R
R-646768-6A1	B12BA195R	R-649368-64A1	B12DA179R		

Table 2. Fuel Pumps with Engines (Model and Serial Number)

Engine Model	Engine S/N	Fuel Pump P/N	Fuel Pump S/N	Engine Model	Engine S/N	Fuel Pump P/N	Fuel Pump S/N	
GTSIO520L	1006597	R-646210-25A2	B12EA149R	IO550B, continued	1006981	R-646766-15A1	B12FA015	
	1006478	R-646210-25A1	B12DA173R		1006704	R-646767-5A1	B12FA022R	
GTSIO520M	1006750	646210-25A3	B12FA051		1006318	R-646767-5A2	B12BA096R	
	1006811	R-646210-25A3	B12EA168R		1006858	R-646768-5A1	B12FA226R	
	1006139	R-646210-25A3	B12AA237R	IO550C	1006637	646767-5A2	B12EA135	
	1006073	R-646210-25A3	B12AA238R		1006638	646767-5A2	B12EA134	
	1006402	R-646210-25A3	B12DA029R		1006743	646767-5A2	B12FA032	
	1006905	R-646210-25A3	B12EA130R		1006740	646767-5A2	B12FA031	
IO360ES	1006804	649368-74A4	B12FA073		1005338	R-646767-5A2	B12FA054R	
	1006366	649368-74A4	B12CA174		1006583	R-646767-5A2	B12EA080R	
	1006389	649368-74A4	B12CA175	IO550E	1006373	646824-7A1	B12CA189	
	1006788	649368-74A4	B12EA072	IO550F	1006761	R-646824-7A3	B12FA071R	
	1006527	649368-74A4	B12CA176	IO550R	1006280	649368-76A1	B12CA026	
	1006783	649368-74A4	B12FA012	LTSIO360KB	1006634	649368-67A1	B12EA133	
	1006782	649368-74A4	B12EA006		1006829	R-649368-67A1	B12EA217R	
	1006565	649368-74A4	B12EA009		1006545	R-649368-67A1	B12EA004R	
	1006805	649368-74A4	B12FA075		1006614	R-649368-67A1	B12EA113R	
	1006781	649368-74A4	B12EA011	LTSIO520AE	1006624	649368-70A2	B12EA119	
	1006822	649368-74A4	B12FA074		1006240	R-649368-70A2	B12BA210R	
	1006832	649368-74A4	B12FA109	TSIO360FB	1006802	649368-63A1	B12FA143	
	1006272	649368-74A4	B12BA068		1006212	R-649368-63A1	B12BA149R	
	1006826	649368-74A4	B12FA110		1006779	R-649368-63A1	B12FA105R	
	1006824	649368-74A4	B12FA200		1006789	R-649368-63A1	B12FA108	
	1006806	649368-74A4	B12FA072		1006425	R-649368-63A1	B12CA212R	
	1006295	649368-74A4	B12BA143		TSIO360KB	1006633	649368-66A2	B12EA132
	1006299	649368-74A4	B12BA067	TSIO360LB	1006900	R-649368-66A1	B12EA067R	
	1006312	649368-74A4	B12BA065	TSIO520C	1006818	R-646768-6A1	B12FA162R	
	1006313	649368-74A4	B12BA009		1006125	R-646768-6A1	B12BA047	
	1006226	R-649368-74A4	B12CA009R	TSIO520E	1006770	R-646210-24A1	B12EA107R	
	1006656	R-649368-74A4	B12EA164R	TSIO520EB	1006454	R-646210-30A2	B12CA037R	
	1006598	R-649368-74A4	B12CA197R		1006796	R-646210-30A2	B12FA135R	
	1006271	649368-74A4	B12BA010	TSIO520G	1006817	646768-6A1	B12FA153	
	IO520MB	N/A	N/A	N/A				
	IO550B	1006556	646766-14A1	B12EA079				
		1006625	646766-15A1	B12EA123				
		1006820	646766-15A1	B12FA161				
1006630		646766-15A1	B12EA030					
1006777		646766-15A1	B12FA087					
1006476		R-646766-15A1	B12EA243R					

Table 2. Fuel Pumps with Engines (Model and Serial Number), continued

Engine Model	Engine S/N	Fuel Pump P/N	Fuel Pump S/N	Engine Model	Engine S/N	Fuel Pump P/N	Fuel Pump S/N
TSIO520H	1006265	646768-6A1	B12CA018	TSIO520VB	1006800	R-646210-27A1	B12FA138R
TSIO520M	1006772	646768-5A1	B12FA088		1006283	R-646210-27A1	B12CA004R
	1006732	646768-5A1	B12FA021		1006560	R-646210-27A1	B12DA148R
	1006816	646768-5A1	B12FA152		1006836	R-646210-27A1	B12FA156R
	1006297	646768-5A1	B12CA068		1006106	R-646210-27A1	B12AA233R
	1006097	646768-5A1	B12AA231		1006561	R-646210-27A1	B12EA078R
	1006321	646768-5A1	B12CA117		1006302	R-649368-58A1	B12CA065
	1006716	646768-5A1	B12EA082	TSIO550C	1006767	R-649368-60A3	B12FA089R
	1006801	R-646768-5A1	B12FA111R	TSIO550E	1006557	649368-60A1	B12EA028
	1006593	R-646768-5A1	B12EA213R	TSIO550G	1006680	R-649368-60A1	B12EA221R
	1006774	R-646768-5A1	B12FA056R	TSIO550K	1006477	649368-60A7	B12BA099
	1006266	R-646768-5A1	B12BA183R		1006162	649368-60A7	B12BA017
1006343	R-646768-5A1	B12CA072R	1006161		649368-60A7	B12BA019	
TSIO520NB	1006715	R-646210-30A4	B12FA026R		1006191	649368-60A7	B12BA016
TSIO520R	1006553	R-646210-30A5	B12EA040R		1006311	649368-60A7	B12BA137
	1006717	R-646210-30A5	B12FA025R		1006469	649368-60A7	B12DA051
	1006821	646768-5A1	B12FA209		1006791	649368-60A7	B12FA045
	1006203	646768-5A1	B12BA114		1006787	649368-60A7	B12FA047
	1006731	646768-5A1	B12FA020		1006786	649368-60A7	B12EA229
	1006201	646768-5A2	B12BA116		1006760	649368-60A7	B12EA228
	1006419	646768-5A2	B12DA031		1006758	649368-60A7	B12FA044
TSIO520T	1006196	R-646768-5A1	B12BA042R		1006690	649368-60A7	B12EA051
	1006672	R-646768-5A1	B12EA205R		1006694	649368-60A7	B12EA052
	1006562	R-646210-28A1	B12EA047R		1006718	649368-60A7	B12EA226
	1006568	R-646210-28A1	B12EA046R	1006719	649368-60A7	B12EA227	
	1006768	R-646210-28A1	B12FA090R	1006720	649368-60A7	B12EA225	
TSIO520UB	1006665	R-646210-28A1	B12EA209R	1006471	649368-60A7	B12CA161	
	1006714	R-646210-28A1	B12FA060R	TSIO550N	1006863	649368-60A7	B12FA182
TSIO520UB	1006748	649368-58A2	B12FA066	TSIO550P	N/A	N/A	N/A
	1006588	R-649368-58A1	B12EA109R				

III. ACTION REQUIRED

Before performing any engine maintenance, perform the following steps to avoid the possibility of an uncommanded engine start.

WARNING

To Prevent the Possibility of Serious Bodily Injury or Death, Verify the following conditions prior to performing any Inspection, Repair, or Movement of the Propeller:

Aircraft Master Power and Magneto SwitchesOFF

Fuel Selector ValveOFF

Throttle Position..... CLOSED

Mixture Control IDLE/CUTOFF

Set Brakes and Place Wheel Chocks Forward and Aft of the Main Landing Gear Tires; Install Aircraft Tie-Downs and Verify Cabin Door Latch is OPEN. Do Not Stand or Place Equipment in the Arc of the Propeller.

A. Inspection

1. Remove engine cowling according to the airframe manufacturers' instructions
2. Use an inspection mirror to determine the part number and serial number of the fuel pump.
 - a. If the part number and serial number of the fuel pump is not identified within "Section II, Tables 1 and 2"; proceed to the "Follow on Maintenance" instructions in Section B.
 - b. If the part number and serial number of the installed fuel pump is identified within "Section II, Tables 1 and 2", then:
 - 1) Remove and replace the fuel pump according to the engine Instructions for Continued Airworthiness.
 - 2) Perform a fuel system operational check according to the engine Instructions for Continued Airworthiness or the latest revision of M-0, Standard Practice Maintenance Manual.
 - 3) Return the faulty fuel pump to Continental Motors for inspection according to Section IV, "FUEL PUMP RETURN INSTRUCTIONS".

B. Follow on Maintenance

1. Perform a visual inspection of the work area and engine compartment for serviceability and cleanliness.
2. Install the aircraft cowling according to the aircraft manufacturer's instructions.
3. Complete engine maintenance records entries as required and return the engine to service.

ISSUED	REVISED	 P.O. Box 90 Mobile, AL 251-436-8299	PAGE NO	DOC NO	REVISION
2013/08/23	2016/11/07		6 of 8	SB13-4	C

IV. FUEL PUMP RETURN INSTRUCTIONS

As noted above, if the fuel pump is identified under “Section II, Tables 1 and 2”, order a new fuel pump from CMI’s Customer Service Department and return the old fuel pump to the address below:

Continental Motors, Inc.
C/O **SB13-4**
8600 Country Road 32
Fairhope, Alabama 36532

V. WARRANTY

The actions required to comply with this bulletin are covered by the applicable engine or part warranty policy in effect at the time the engine and/or part was purchased. Affected engines and parts can be determined by reviewing the aircraft/engine records. Continental Motors reserves the right to request copies of invoices and maintenance records to verify warranty applicability.

NOTE: Visit the Continental Motors, Inc. web site at www.continentalmotors.aero to obtain copies of CMI Warranty Policies.

Complete the attached **Compliance Form SB13-4, along with a copy of the work invoice, original purchase receipt for the part and a copy of the repair agency’s W-9**, immediately upon completion for reimbursement.

Labor allowance: **3 hours** at published shop rate.

Submit the entire completed compliance package **between August 1, 2013 and May 1, 2014** via postal service or fax to the following:

Continental Motors Inc.
C/O **SB13-4**
P.O. Box 90
Mobile, AL 36601
or via Fax to 1 (251) 436-8270

ISSUED	REVISED	 P.O. Box 90 Mobile, AL 251-436-8299	PAGE NO	DOC NO	REVISION
2013/08/23	2016/11/07		7 of 8	SB13-4	C

INTENTIONALLY LEFT BLANK



ISSUED	REVISED	 P.O. Box 90 Mobile, AL 251-436-8299	PAGE NO	DOC NO	REVISION
2013/08/23	2016/11/07		8 of 8	SB13-4	C