



The New Piper Aircraft, Inc.
2926 Piper Drive
Vero Beach, Florida, U.S.A. 32960

SERVICE No. 1006 BULLETIN

PIPER CONSIDERS COMPLIANCE MANDATORY

DATE: August 15, 1997 (S)

SUBJECT:

**Corrosion Inspection of Main Spar Behind
Fuel Tanks**

MODELS AFFECTED:

PA-28-140 Cherokee
PA-28-150/160/180 Cherokee
PA-28-151 Warrior
PA-28-161 Warrior II
PA-28-161 Warrior III
PA-28-161 Cadet
PA-28-181 Archer II

PA-28-181 Archer III
PA-28-235 Cherokee
PA-28-236 Dakota

PA-28-201T Turbo Dakota
PA-28R-180 Arrow
PA-28R-200 Arrow/Arrow II
PA-28R-201 Arrow III
PA-28R-201 Arrow
PA-28R-201T Turbo Arrow III
PA-28R-201T Turbo Arrow
PA-28RT-201 Arrow IV
PA-28RT-201T Turbo Arrow IV

PA-32-260 Cherokee Six
PA-32-300 Cherokee Six 300
PA-32-301 Saratoga

PA-32-301T Turbo Saratoga
PA-32R-300 Lance
PA-32RT-300 Lance II
PA-32RT-300T Turbo Lance II
PA-32R-301 Saratoga SP

PA-32R-301 Saratoga II HP

PA-32R-301T Turbo Saratoga SP

PA-32R-301T Saratoga II TC

SERIAL NUMBERS AFFECTED:

28-20000 through 28-7725290
28-1 through 28-7505259 & 28-E13
28-7415001 through 28-7715314
28-7716001 through 28-8616057, and
2816001 through 2816119, 2842001 and up
2841001 through 2841365 and up
28-7690001 through 28-8690062,
2890001 through 2890205
2890206 through 2890231, 2843001 and up
28-10001 through 28-7710089 & 28-E11
28-7911001 through 28-8611008,
2811001 through 2811038, 2811040 through
2811050, and up
28-7921001 through 28-7921095,
28R-30001 through 28R-7130013
28R-35001 through 28R-7635462
28R-7737001 through 28R-7837319,
2837001 through 2837061, 2844001 & up
28R-7703001 through 28R-7803374 and
2803001 through 2803012
28R-7918001 through 28R-8218026,
28R-7931001 through 28R-8631005
2831001 through 2831038
32-1 through 32-7800008
32-40000 through 32-7940290
32-8006001 through 32-8606023,
3206001 through 3206088
32-8024001 through 32-8424002
32R-7680001 through 32R-7880068
32R-7885001 through 32R-7985105
32R-7887001 through 32R-7987126
32R-8013001 through 32R-8613006
3213001 through 3213041
3213029, 3213042 through 3213103,
3246001 and up
32R-8029001 through 32R-8629006,
3229001, 3229002 and 3229003
3257001 and up

(OVER)
ATA: 0530

COMPLIANCE TIME: To coincide with the next regularly scheduled maintenance inspection upon reaching seven (7) calendar years time in service and at each seven (7) calendar years thereafter. If beyond seven (7) calendar years time in service, to coincide with the next regularly scheduled maintenance inspection but not to exceed the next one-hundred (100) hours time in service and at each seven (7) calendar years thereafter.

APPROVAL: The technical contents of this Service Bulletin have been approved by the Federal Aviation Administration (F.A.A.).

PURPOSE: Recent reports of significant corrosion on the spar cap behind the fuel tanks in PA-28 and PA-32 series aircraft have prompted the creation of additional guidance beyond that contained in current Service/Maintenance Manuals. While the Service/Maintenance Manuals cover this area for corrosion inspection, thorough inspection is often missed due to insufficient disassembly or difficulty in gaining access to the area of inspection. This Service Bulletin is intended to supplement the existing corrosion inspection requirements by detailing specific areas for a more thorough examination and by recommendations for preventative treatment. In addition, a calendar time replacement of the flexible fuel vent hoses behind the fuel tank is established which coincide with the removal of the fuel tank required by this Service Bulletin. If not detected, significant corrosion in the spar cap area may affect the structural integrity of the spar which, if left uncorrected, may compromise the wing structure.

This Service Bulletin provides an initial and repetitive inspection requirement to detect, treat, and, if necessary, eliminate damaged parts by replacement or field repair. In addition, this Service Bulletin requires repetitive replacement of flexible fuel vent hoses.

INSTRUCTIONS: (Refer to the applicable Service/Maintenance Manual as required)

Note

Service Bulletin 646A must be complied with prior to or in conjunction with this Service Bulletin. *(Check for model and serial number applicability.)*

Note

Refer to the model charts on page 4 and 5. Each chart addresses the inspection requirement of a family group of Piper aircraft. For example PA-28 series, addresses aircraft from the Cherokees to Arrows.

1. Identify the chart which best fits your aircraft.
2. Drain and remove the fuel tanks from the aircraft wing. Accomplish the inspection instructions contained on the chart. **CAUTION:** *Great care must be taken when fuel tanks are removed as fuel tanks are wing structure.*
3. If corrosion is detected and is beyond minor surface oxidation, replace or repair the affected parts before continuing with this Service Bulletin. Utilize a current revision of the Piper Parts Catalog to determine the appropriate part numbers for any required replacement part. *Although this Service Bulletin addresses corrosion, the general condition of the inspected area must also be considered. Should other discrepancies be noted such as cracking, wear etc., the affected parts must be repaired or replaced. Repairs are not available from Piper, utilize AC43.13 or other FAA approved methods for an acceptable means of repair.*

Note

Prior to application of corrosion preventative, assure that any part which may have been replaced or repaired is clean and that the paint or primer is thoroughly cured.

4. Remove and replace flexible vent hoses at the fuel tanks and outlets (as applicable). Normal replacement of other flexible fuel lines are at 8 years or 1000 hours, however, it is recommended but not required that these lines be replaced at this time. *(Any flexible line which fails inspection must be replaced regardless of time in service.)*
5. To coincide with or upon the completion of the inspections required by this Service Bulletin, treat the affected areas utilizing Dinotrol AV 8, Piper Part Number 89500-800. Follow the instructions on the container. *One container should be sufficient for PA-28's while two containers are required for PA-32's.*

INSTRUCTIONS: (Cont'd)

6. Close all areas where access has been gained.
7. Prior to returning the aircraft to service, it will be necessary to perform operational checks on any area or system disturbed by inspection, repair or part replacement. Refer to the appropriate Service or Maintenance Manual chapter for the applicable system for detailed information. (i.e. fuel quantity, fuel feed, etc.).
8. Upon successful completion of these instructions make an appropriate logbook entry of compliance with this Service Bulletin.

MATERIAL REQUIRED:

As required by inspection one or more Containers of Dinotrol AV 8, Piper Part Number 89500-800. Note: *This material required section does not address fuel vent hoses or any part which may need to be replaced as the result of this inspection. The part number must be obtained by referring to the latest revision of the Aerofiche Parts Catalog applicable to your model aircraft.*

AVAILABILITY OF PARTS:

Your Piper Field Service Facility.

SUMMARY:

There is NO factory participation available for compliance with this Service Bulletin.

Please contact your factory authorized Piper Field Service Facility to make arrangements for compliance with this Service Bulletin in accordance with the compliance time indicated and to obtain additional information concerning any applicable factory participation.

NOTE:

If you are no longer in possession of this aircraft, please forward this information to the present owner/operator and notify the factory of address/ownership corrections. Changes should include aircraft model, serial number, current owner's name and address.

Corrections/Changes should be directed to:

The New Piper Aircraft, Inc.
ATTN: Customer Services
2926 Piper Drive
Vero Beach, FL 32960

PA 28 & PA 28R SERIES CHART (Typical)

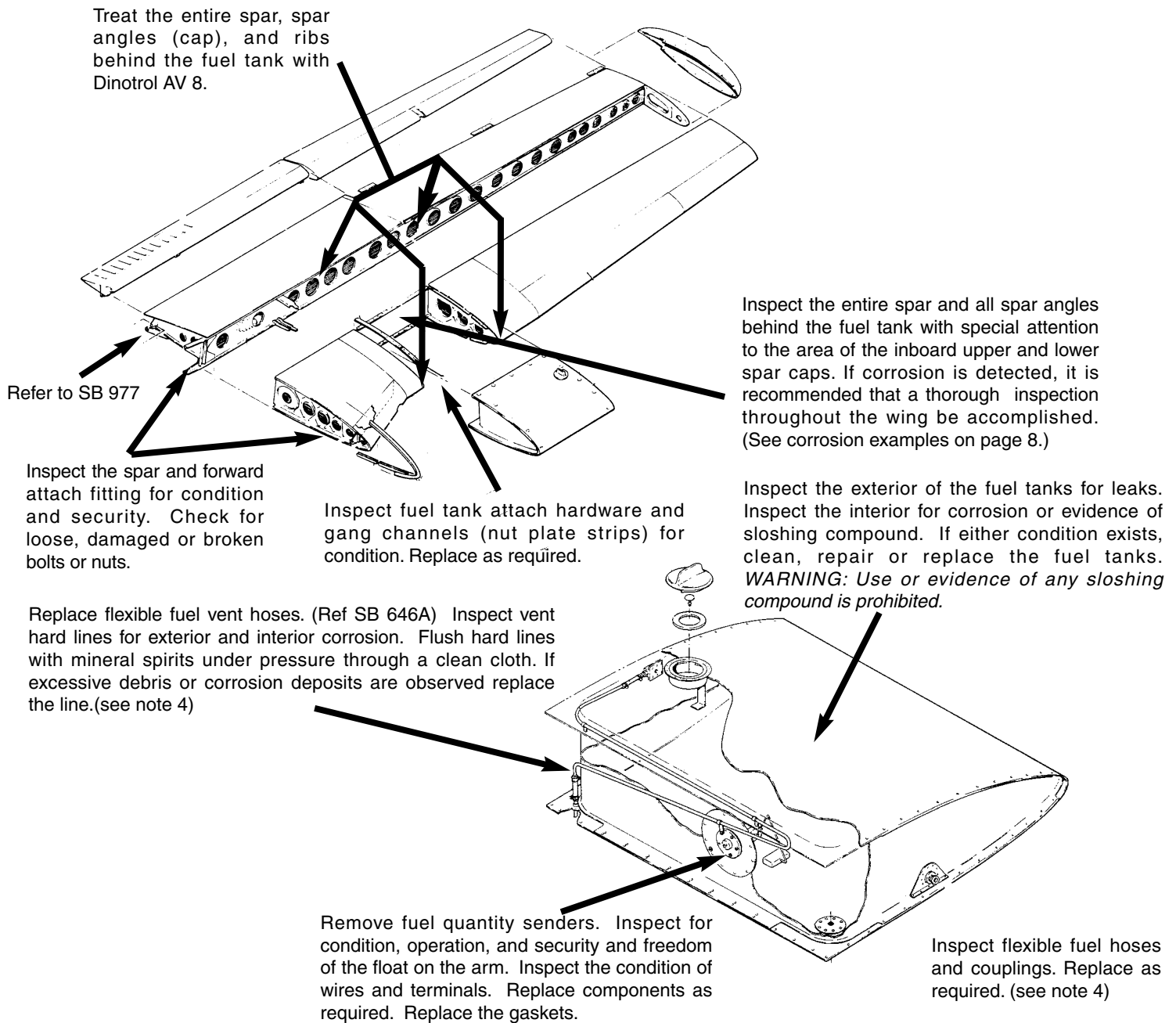

NOTES

1. All inspections are for corrosion (intergranular, exfoliation etc.) however, any area or part should also be checked for other anomalies such as damage, cracking or wear. Should any part or area be determined to be defective in any way, an FAA approved repair or replacement of that area or part must occur.
2. All inspections appearing above apply to fixed gear, retractable gear, or "T" tailed aircraft unless noted. Some inspection areas may be slightly different on different models. (Such as the vent and fuel line routing, etc.)
3. Inspection means to disassemble as necessary to determine the condition. This includes gaining access as necessary by removing panels or skin, removing rivets, removing paint and or the use of NDT as required.
4. All flexible fuel vent lines must be replaced every seven years or 1000 hours (first to occur). Other flexible fuel lines and couplings must be replaced every eight years, (seven recommended) or at engine overhaul (first to occur).
5. Refer to the latest revision of the applicable Piper Parts Catalog for part numbers as required. Refer to the latest revision of the applicable Piper Service or Maintenance Manual for removal, installation and testing.

PA 32 & PA 32R SERIES CHART (Early)

Inspect the entire spar and all spar angles behind the fuel tank with special attention to the area of the inboard upper and lower spar caps. If corrosion is detected, it is recommended that a thorough inspection throughout the wing be accomplished. (See corrosion examples on page 8.)

Treat the entire spar, spar angles (cap), and ribs behind the fuel tank with Dinotrol AV 8.

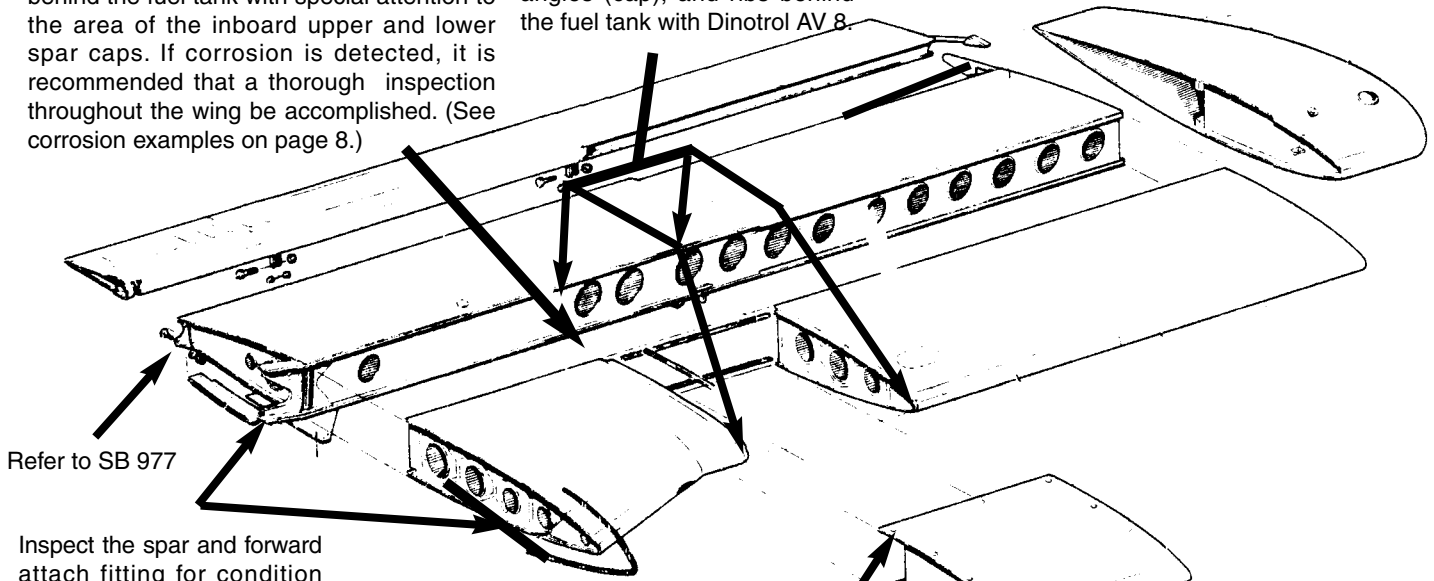

Refer to SB 977

Inspect the spar and forward attach fitting for condition and security. Check for loose, damaged or broken bolts or nuts.

Inspect fuel tank attach hardware and gang channels (nut plate strips) for condition. Replace as required.

Inspect flexible fuel hoses and couplings. Replace as required. (see note 4)

Replace flexible fuel vent hoses. (Ref SB 646A) Inspect vent hard lines for exterior and interior corrosion. Flush hard lines with mineral spirits under pressure through a clean cloth. If excessive debris or corrosion deposits are observed replace the line. (see note 4)

Remove fuel quantity senders. Inspect for condition, operation, and security and freedom of the float on the arm. Inspect the condition of wires and terminals. Replace components as required. Replace the gaskets.

Inspect the exterior of the fuel tanks for leaks. Inspect the interior for corrosion or evidence of sloshing compound. If either condition exists, clean, repair or replace the fuel tanks. **WARNING: Use or evidence of any sloshing compound is prohibited.**

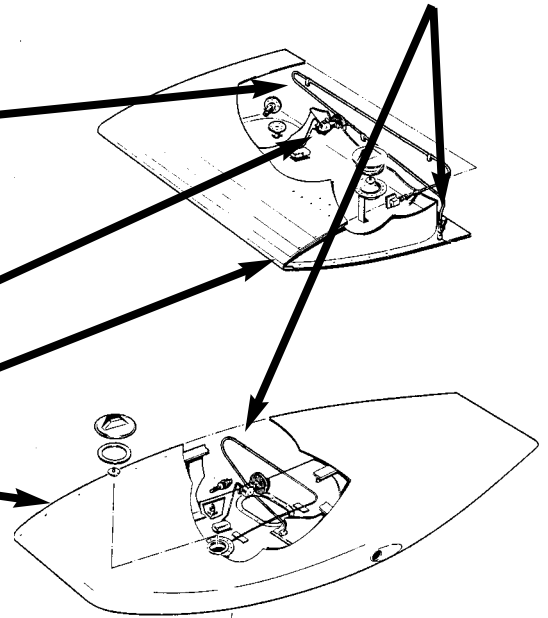

NOTES

1. All inspections are for corrosion (intergranular, exfoliation etc.) however, any area or part should also be checked for other anomalies such as damage, cracking or wear. Should any part or area be determined to be defective in any way, an FAA approved repair or replacement of that area or part must occur.
2. All inspections appearing above apply to fixed gear, retractable gear, or "T" tailed aircraft unless noted. Some inspection areas may be slightly different on different models. (Such as the vent and fuel line routing, etc.)
3. Inspection means to disassemble as necessary to determine the condition. This includes gaining access as necessary by removing panels or skin, removing rivets, removing paint and or use of NDT as required.
4. All flexible fuel vent lines must be replaced every seven years or 1000 hours (first to occur). Other flexible fuel lines and couplings must be replaced every eight years, (seven recommended) or at engine overhaul (first to occur).
5. Refer to the latest revision of the applicable Piper Parts Catalog for part numbers as required. Refer to the latest revision of the applicable Piper Service or Maintenance Manual for removal, installation and testing.

PA 32, PA 32R & (RT) SERIES CHART

Inspect the entire spar and all spar angles behind the fuel tank with special attention to the area of the inboard upper and lower spar caps. If corrosion is detected, it is recommended that a thorough inspection throughout the wing be accomplished. (See corrosion examples on page 8.)

Treat the entire spar, spar angles (cap), and ribs behind the fuel tank with Dinotrol AV 8.

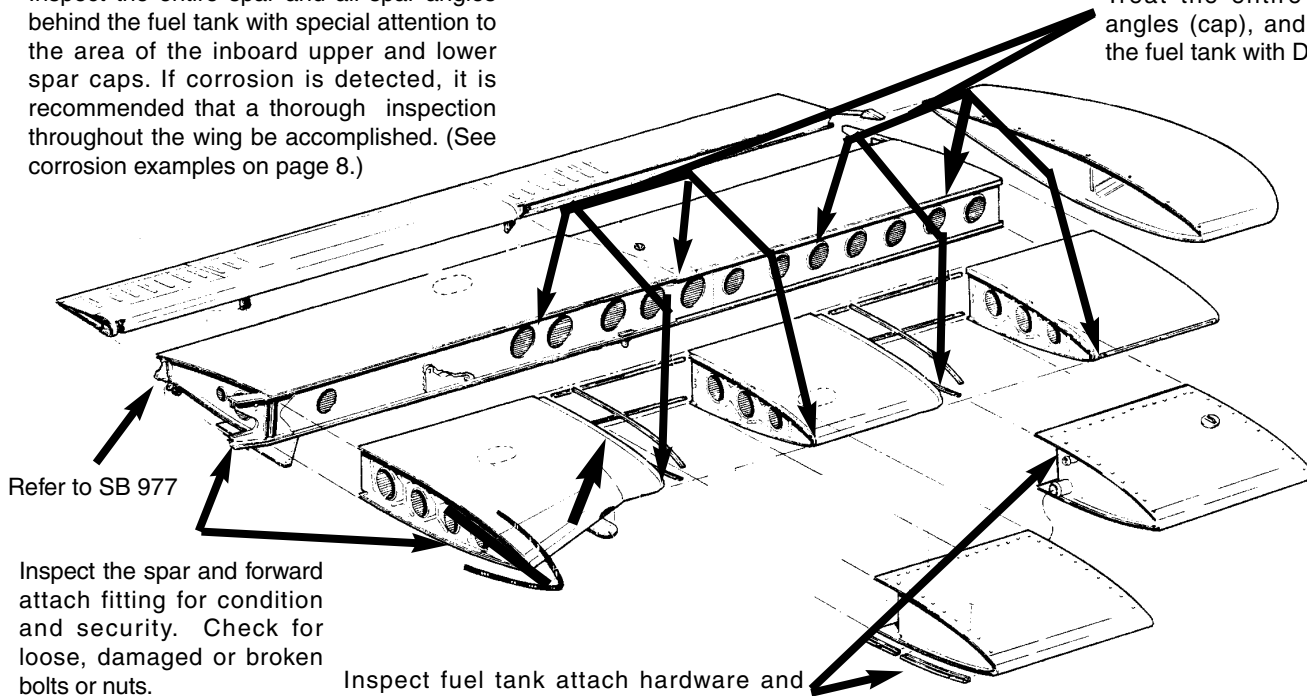

Refer to SB 977

Inspect the spar and forward attach fitting for condition and security. Check for loose, damaged or broken bolts or nuts.

Inspect fuel tank attach hardware and gang channels (nut plate strips) for condition. Replace as required.

Remove fuel quantity senders. Inspect for condition, operation, and security and freedom of the float on the arm. Inspect the condition of wires and terminals. Replace components as required. Replace the gaskets.

Replace flexible fuel vent hoses. (Ref SB 646A) Inspect vent hard lines for exterior and interior corrosion. Flush hard lines with mineral spirits under pressure through a clean cloth. If excessive debris or corrosion deposits are observed replace the line. (see note 4)

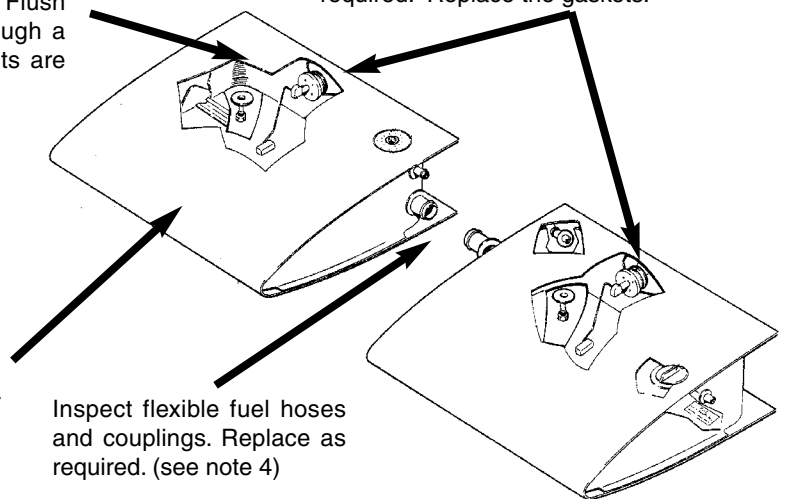

Inspect the exterior of the fuel tanks for leaks. Inspect the interior for corrosion or evidence of sloshing compound. If either condition exists, clean, repair or replace the fuel tanks. **WARNING: Use or evidence of any sloshing compound is prohibited.**

Inspect flexible fuel hoses and couplings. Replace as required. (see note 4)

NOTES

1. All inspections are for corrosion (intergranular, exfoliation etc.) however, any area or part should also be checked for other anomalies such as damage, cracking or wear. Should any part or area be determined to be defective in any way, an FAA approved repair or replacement of that area or part must occur.
2. All inspections appearing above apply to fixed gear, retractable gear, or "T" tailed aircraft unless noted. Some inspection areas may be slightly different on different models. (Such as the vent and fuel line routing, etc.)
3. Inspection means to disassemble as necessary to determine the condition. This includes gaining access as necessary by removing panels or skin, removing rivets, removing paint and or use of NDT as required.
4. All flexible fuel vent lines must be replaced every seven years or 1000 hours (first to occur). Other flexible fuel lines and couplings must be replaced every eight years, (seven recommended) or at engine overhaul (first to occur).
5. Refer to the latest revision of the applicable Piper Parts Catalog for part numbers as required. Refer to the latest revision of the applicable Piper Service or Maintenance Manual for removal, installation and testing.

PA 32 & PA 32R SERIES CHART (Tapered Wing)

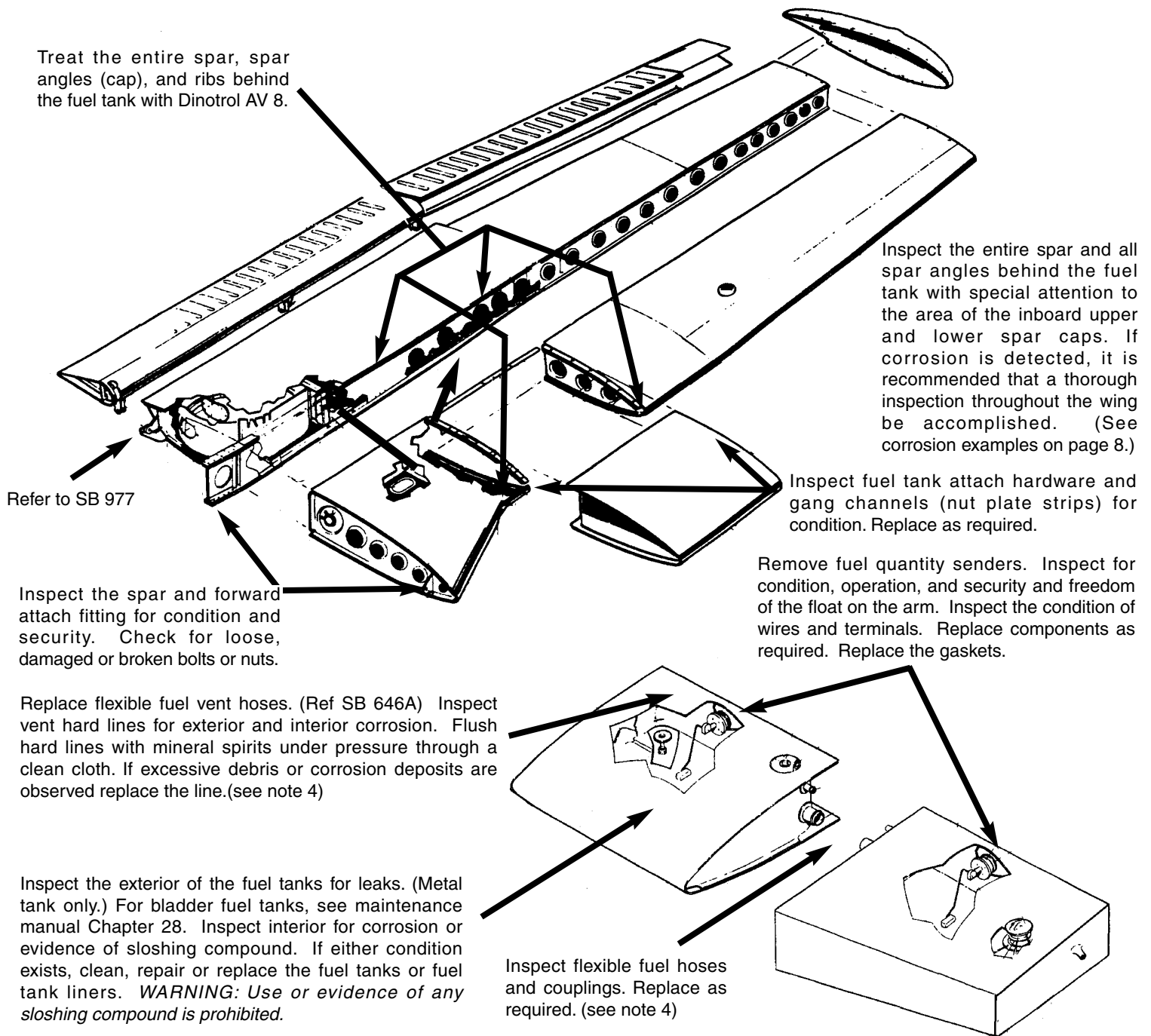

NOTES

1. All inspections are for corrosion (intergranular, exfoliation etc.) however, any area or part should also be checked for other anomalies such as damage, cracking or wear. Should any part or area be determined to be defective in any way, an FAA approved repair or replacement of that area or part must occur.
2. All inspections appearing above apply to fixed gear, retractable gear, or "T" tailed aircraft unless noted. Some inspection areas may be slightly different on different models. (Such as the vent and fuel line routing, etc.)
3. Inspection means to disassemble as necessary to determine the condition. This includes gaining access as necessary by removing panels or skin, removing rivets, removing paint and or use of NDT as required.
4. All flexible fuel vent lines must be replaced every seven years or 1000 hours (first to occur). Other flexible fuel lines and couplings must be replaced every eight years, (seven recommended) or at engine overhaul (first to occur).
5. Refer to the latest revision of the applicable Piper Parts Catalog for part numbers as required. Refer to the latest revision of the applicable Piper Service or Maintenance Manual for removal, installation and testing.

**CORROSION EXAMPLES
(Spar Cap and Tank Bay)
below**

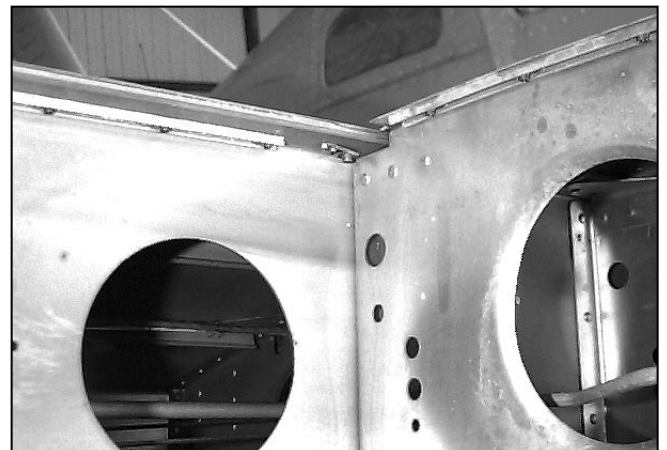
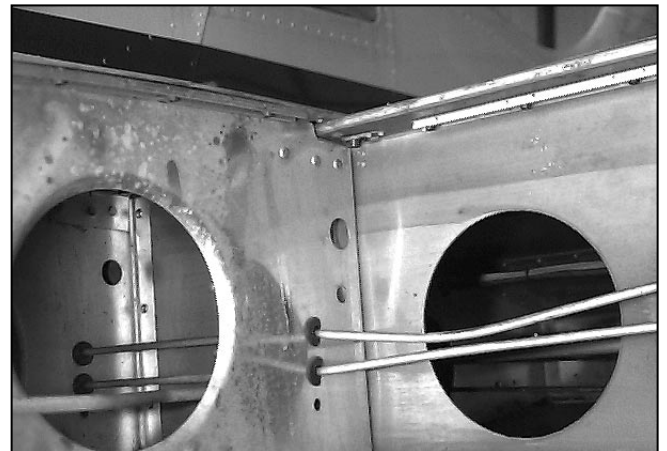
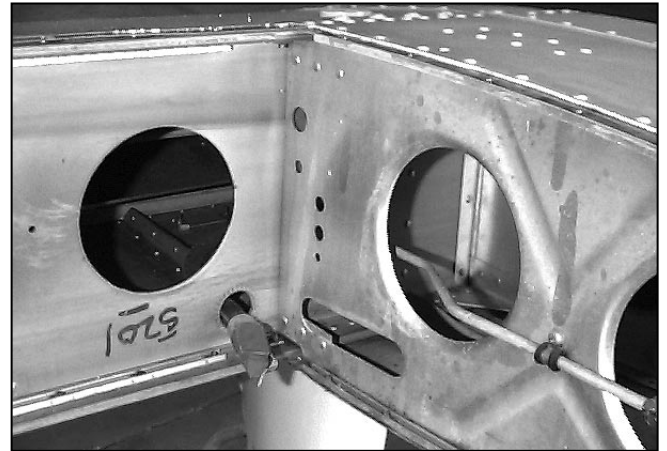
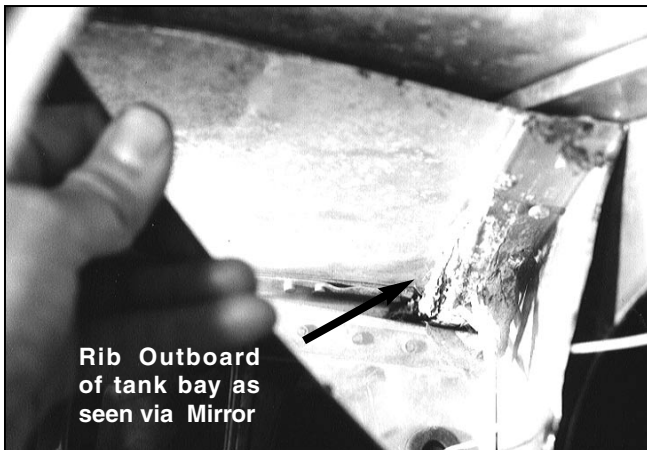
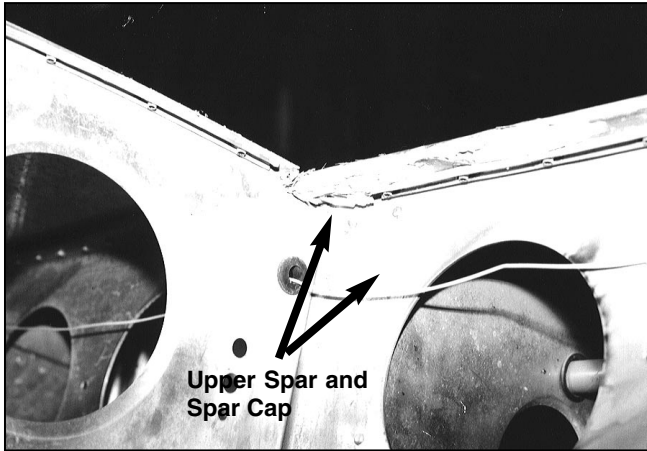

**TYPICAL CLEAN INSPECTION
(Spar Cap and Tank Bay)
above**